

UPT-640
(as of SW 100)

®

Operating Instructions



The UPT-640 temperature controller is a key component in an ULTRA-PULSE system, because it is responsible for all heat management functions, i.e. controlling the temperature of the heating element and ensuring that this highly dynamic impulse heatsealing method is accurately timed.

Important features

- Microprocessor technology
- LC display (green), 4 lines, 20 characters, (multilingual)
Alternatively:
VF display (blue), 4 lines, 20 characters, (multilingual)
- Automatic zero calibration (AUTOCAL)
- Automatic configuration of the secondary voltage and current ranges (AUTORANGE)
- Booster connection as standard
- Heatsealing band alloy and temperature range selectable
- Time control, heatsealing time and cooling time settable
- Externally or internally generated release impulse with programmable parameters
- Configurable relay output, e.g. "end of cycle"
- Time or temperature-controlled cooling phase
- Signal output for "Temperature OK"
- 0...10VDC analog input for set point selection, electrically isolated
- 0...10VDC analog output for ACTUAL temperature, electrically isolated
- 24VDC control inputs for START, AUTOCAL, RELEASE and RESET, electrically isolated
- Alarm function with fault diagnosis
- Cooling system monitored

Contents

1	Safety and warning notes	3	9	Controller functions	23
1.1	Use	3	9.1	Indicators and controls	23
1.2	Heating element	3	9.2	Display	23
1.3	Impulse transformer	3	9.3	Navigation in the menus	25
1.4	Current transformer PEX-W2/-W3	3	9.4	Menu structure	27
1.5	Line filter	3	9.5	Two-digit numbering system up to software revision 022	29
1.6	Warranty provisions	3	9.6	Temperature setting (set point selection)	30
1.7	Standards / CE marking	4	9.7	Temperature indication/actual value output	31
2	Application	4	9.8	Automatic zero calibration (AUTOCAL)	32
3	System description	5	9.9	"START" signal (HEAT)	33
3.1	Temperature controller	5	9.10	"RESET" signal	34
3.2	Current transformer PEX-W2/-W3	6	9.11	Correction factor Co	34
3.3	Booster	6	9.12	Maximum starting temperature	35
4	Accessories and modifications	7	9.13	Cycle counter	35
4.1	Accessories	7	9.14	Hold mode	35
4.2	Modifications (MODs)	8	9.15	Measuring impulse duration	36
5	Technical data	9	9.16	Locking the "HAND" key	36
6	Dimensions/front panel cutout	11	9.17	Temperature unit Celsius / Fahrenheit (as of software revision 103)	36
7	Installation	12	9.18	Disabling the Configuration menu	37
7.1	Installation steps	12	9.19	Setting the display brightness (VF display only)	37
7.2	Installation procedure	12	9.20	Undervoltage detection	37
7.3	Power supply	13	9.21	Diagnostic interface/visualization software	38
7.4	Line filter	14	9.22	Booster connection	38
7.5	Current transformer PEX-W3	14	9.23	Time control (timer function)	38
7.6	Wiring diagram (standard)	15	9.24	Release impulse	44
7.7	Wiring diagram with booster connection	16	9.25	System monitoring/alarm output	46
8	Startup and operation	17	9.26	Error messages	46
8.1	Front view of the controller	17	9.27	Fault areas and causes	50
8.2	Rear view of the controller	17	10	Factory settings	51
8.3	Controller configuration	18	10.1	Customer settings	52
8.4	Heating element	21	11	Maintenance	52
8.5	Startup procedure	21	12	How to order	53
			13	Index	54

1 Safety and warning notes

This CIRUS temperature controller is manufactured according to DIN EN 61010-1. In the course of its manufacture it passed through quality assurance, whereby it was subjected to extensive inspections and tests.

It left the factory in perfect condition.

The recommendations and warning notes contained in these operating instructions must be complied with, in order to guarantee safe operation.

The device can be operated within the limits indicated in the "Technical Data" without impairing its operational safety. Installation and maintenance may only be performed by technically trained, skilled persons who are familiar with the associated risks and warranty provisions.

1.1 Use

CIRUS temperature controllers may only be used for heating and temperature control of heatsealing elements which are expressly suitable for them, and providing the regulations, notes and warnings contained in these instructions are complied with.

 In case of non-compliance or use contrary to the intended purpose, there is a risk that safety will be impaired or that the heatsealing element, electrical wiring, transformer etc. will overheat. Ensuring such compliance is the personal responsibility of the user.

1.2 Heating element

The temperature coefficient of a CIRUS temperature controller is specially adapted to CIRUS heating elements.

 The controller is not allowed to be operated with any other heatsealing bands because they could be overheated and damaged beyond repair.

1.3 Impulse transformer

A suitable impulse transformer is necessary to ensure that the control loop functions perfectly. This transformer must be designed according to VDE 0570/EN 61558 (isolating transformer with reinforced

insulation) and have a one section bobbin. When the impulse transformer is installed, suitable shock protection must be provided in accordance with the national installation regulations for electrical equipment. In addition, water, cleaning solutions and conductive fluids must be prevented from seeping into the transformer.

 Incorrect installation of the impulse transformer impairs electrical safety.

1.4 Current transformer PEX-W2/-W3

The current transformer supplied with the CIRUS temperature controller is an integral part of the control system.

 Only the original ROPEX PEX-W2 or PEX-W3 current transformer may be used. Other transformers may cause the equipment to malfunction.

The current transformer may only be operated if it is connected to the CIRUS temperature controller correctly (see section 9, "Startup and operation"). The relevant safety instructions contained in section 8.3, "Power supply", must be obeyed. External monitoring modules can be used in order to additionally increase operating safety. They are not included in the scope of supply of the standard control system and are described in a separate document.

1.5 Line filter

The use of an original ROPEX line filter is mandatory in order to comply with the standards and provisions mentioned in section 1.7 "Standards / CE marking" on page 4. This device must be installed and connected according to the instructions contained in section 8.3, "Power supply" as well as the separate documentation enclosed with the line filter.

1.6 Warranty provisions

The statutory provisions for warranties apply for a period of 12 months following the delivery date. All devices are tested and calibrated in the factory. Devices that have been damaged due to faulty

connections, dropping, electrical overloading, natural wear, incorrect or negligent handling, chemical influences or mechanical overloading as well as devices that have been modified, relabeled or otherwise altered by the customer, for example in an attempt to repair them or install additional components, are excluded from the warranty.

Warranty claims must be examined in the factory and approved by ROPEX.

1.7 Standards / CE marking

The controller described here complies with the following standards, provisions and directives:

DIN EN 61010-1 (VDE 0411-1)	Safety provisions for electrical measuring, control and laboratory devices (low voltage directive). Overvoltage category III, pollution severity 2, safety class II.
DIN EN 60204-1	Electrical equipment of machines (machinery directive)
EN 50081-1	EMC interference emissions according to EN 55011, group 1, class B
EN 50082-2	EMC interference immunity: ESDs, RF radiation, bursts, surges.

2 Application

This CIRUS temperature controller is an integral part of the "series 600". Its sole purpose is to control the temperature of CIRUS/UPT heating elements, which are used mainly for impulse-heatsealing PP and PE films.

Compliance with these standards and provisions is only guaranteed if original accessories and/or peripheral components approved by ROPEX are used. If not, then the equipment is operated on the user's own responsibility.

The CE marking on the controller confirms that the device itself complies with the above-mentioned standards.

It does not imply, however, that the overall system also fulfils these standards.

It is the responsibility of the machine manufacturer and of the user to verify the completely installed, wired and operationally ready system in the machine with regard to its conformity with the safety provisions and the EMC directive (see also section 8.3, "Power supply"). If peripheral components (e.g. the transformer or the line filter) from other manufacturers are used, no functional guarantee can be provided by ROPEX.

The most important applications are packaging machines, pouch-making machines, splicers, machines for making pharmaceutical and medical products etc.

3 System description

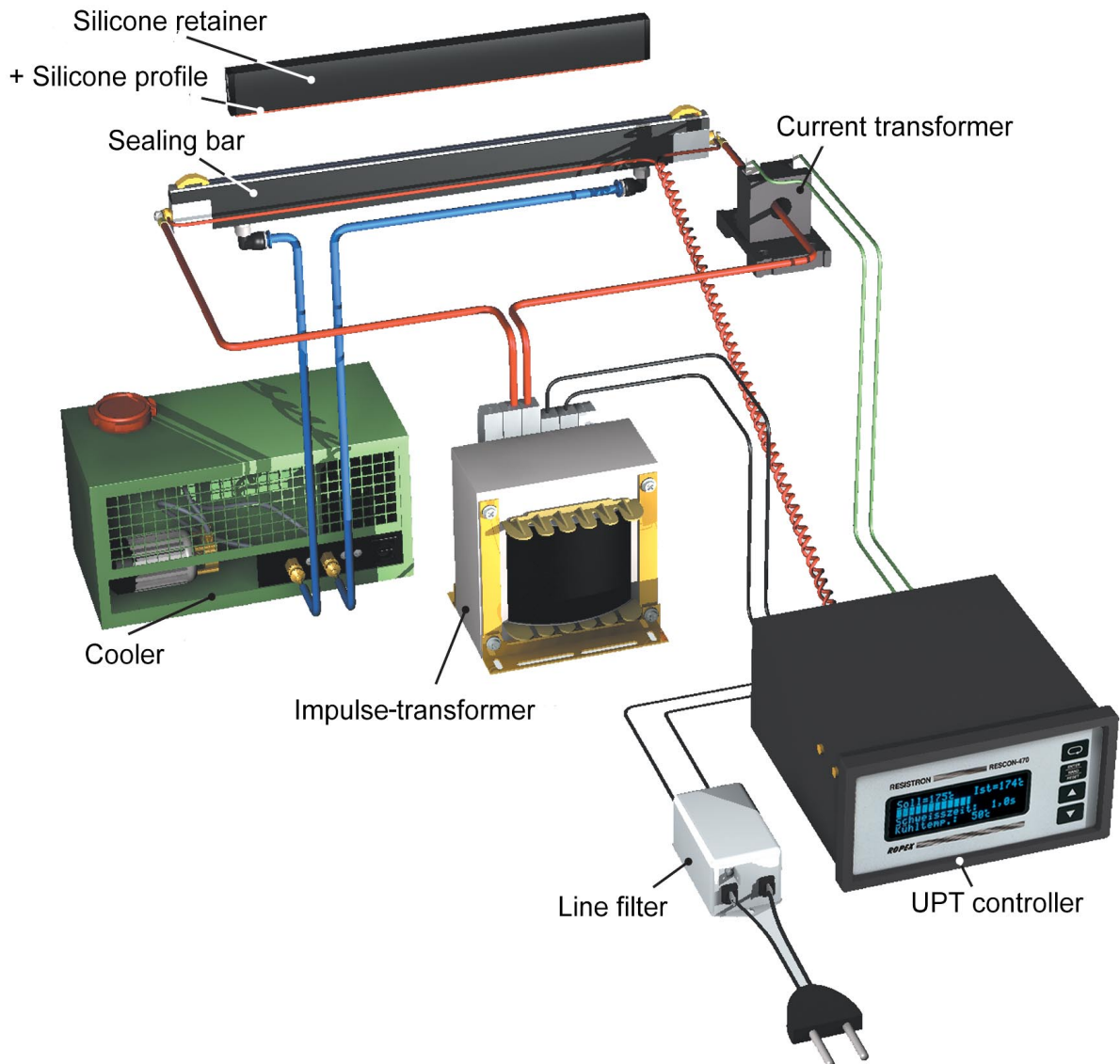

The basic design of the overall system is shown in the diagram above.

CIRUS heating elements, and in particular UPT heating elements, are high-performance systems which operate efficiently and reliably providing all the components in the control loop are optimally tuned to one another – and to the task at hand. Exact compliance with the installation and wiring instructions is essential. The system has been evolved and optimized by ROPEX GmbH in an intensive development process. Users who follow our technical recommendations will profit from the unique functionality of this technology, which reduces the customer's effort for installation, commissioning and maintenance to a minimum.

3.1 Temperature controller

The controller calculates the resistance of the heating element by measuring the current and voltage at a high sampling rate (= line frequency), compares it with the set point and – if the difference is not 0 – adjusts the heating current with the help of a phase angle-controlled transformer so that set = actual.

The fact that purely electrical variables are measured in quick succession and the small mass of the heating

layer of the UPT heating element together result in a highly dynamic, thermo-electrical control loop.

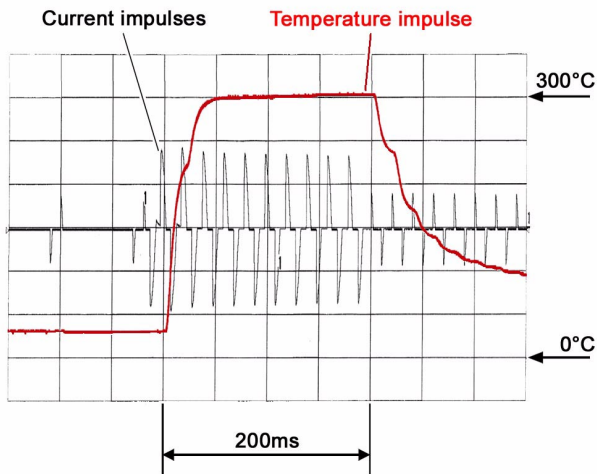

Thanks to its microprocessor based technology, the controller features an optimized control algorithm as well as numerous functions tailored to the various tasks, such as "AUTOCAL", TIMER functions, RELEASE IMPULSE, ALARM with fault diagnosis etc. These are described in detail below.

An easy-to-read, 4-line, multilingual display visualizes all parameters, measured values and states. The con-

troller can also interact with external controllers (PLC, IPC etc.) via the analog INPUTS and OUTPUTS.

The UPT-640 (as of SW 100) controller is designed for installation in a front panel cutout, but can also be accommodated in the electrical cabinet using an adapter for top hat rail mounting (↪ "Adapter for top hat rail mounting, HS-Adapter-01" on page 8).

3.2 Current transformer PEX-W2/-W3

The PEX-W2 current transformer supplied with the CIRUS UPT-640 (as of SW 100) controller is an integral part of the control system. Only this original ROPEX current transformer is allowed to be used.

Never attempt to operate the current transformer with open connections!

3.3 Booster

If the maximum load exceeds the rated current of the controller (↪ section 5 "Technical data" on page 9), an external switching amplifier (booster) must be used (↪ section 4.1 "Accessories" on page 7).

The other system components – UPT sealing bars, transformers, filter, cooler etc. – are described in separate brochures.





4 Accessories and modifications

A wide range of compatible accessories and peripheral devices are available for the CIRUS temperature controller UPT-640 (as of SW 100). They allow it to be optimally adapted to your specific heatsealing application and to your plant's design and operating philosophy.

4.1 Accessories

The products described below are only a few of the wide range of accessories available for CIRUS temperature controllers (☞ "Accessories" leaflet).

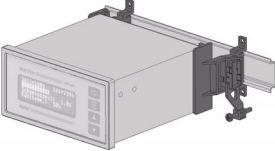
	<p>Analog temperature meter ATR-x For front panel mounting or mounting on a top hat rail (DIN TS35). Analog indication of the ACTUAL temperature of the heatsealing band in °C. The meter damping of the unit is optimized for the abrupt temperature changes that occur in impulse mode.</p>
	<p>Digital temperature meter DTR-x For front panel mounting or mounting on a top hat rail (DIN TS35). Digital indication of the ACTUAL temperature of the heatsealing band in °C, with HOLD function.</p>
	<p>Line filter LF-xx480 Essential in order to ensure CE conformity. Optimized for the CIRUS temperature controller.</p>
	<p>Impulse transformer ITR-x Designed according to VDE 0570/EN 61558 with a one-section bobbin. Optimized for impulse operation with CIRUS temperature controllers. Specified according to the heatsealing application (☞ ROPEX Application Report).</p>
	<p>Communication interface CI-USB-1 Interface for connecting a RESISTRON temperature controller with diagnostic interface (DIAG) to the PC (USB port). Associated PC visualization software for displaying setting and configuration data, and for recording SET and ACTUAL temperatures in real time.</p>
	<p>Booster B-xxx400 External switching amplifier, necessary for high primary currents (continuous current > 5A, pulsed current > 25A).</p>

	<p>Monitoring current transformer For detecting frame short-circuits on the heatsealing band. Used as an alternative to the standard PEX-W2/-W3 current transformer.</p>
	<p>Transparent front cover TFA-1 For increasing the degree of protection on the front of the controller to IP65. Also facilitates applications in the food technology sector (GMP).</p>
	<p>Adapter for top hat rail mounting, HS-Adapter-01 For mounting the CIRUS temperature controller UPT-640 (as of SW 100) on a top hat rail (DIN TS35). Allows the controller to be installed in the electrical cabinet, for instance, where it is only accessible to authorized persons.</p>
	<p>Lockable door TUER-S/K-1 Transparent door (with lock) for mounting on the bezel of the controller. The display is clearly legible at all times. The keyboard can only be operated, however, by authorized persons in possession of a key.</p>
	<p>Measurement cable UML-1 Twisted measurement cable for the U_R voltage measurement. Trailing cable, halogen and silicone-free.</p>

4.2 Modifications (MODs)

Owing to its universal design, the CIRUS temperature controller UPT-640 (as of SW 100) is suitable for a very wide range of heatsealing applications.

One modification (MOD) is available for the CIRUS temperature controller UPT-640 (as of SW 100) for implementing special applications.

MOD 01

Amplifier for low secondary voltages ($U_R = 0.25 \dots 16 \text{VAC}$). This modification is necessary, for example, for very short or low-resistance heating elements.

5 Technical data

Type of construction	Housing for front panel mounting Dimensions (W x H): 144 x 72mm; depth: 161mm (incl. terminals)
Line voltage	230VAC version: 220VAC -15%...240VAC +10% (equivalent to 187...264VAC) 400VAC version: 380VAC -15%...415VAC +10% (equivalent to 323...456VAC) depending on device version (↳ Kap. 12 „How to order“ auf Seite 53)
Line frequency	47...63Hz, automatic adjustment to frequencies in this range
Heatsealing band type and temperature range	The temperature range and temperature coefficient can be set independently of one another in the Configuration menu: Temperature range: 200°C, 300°C, 400°C, 500°C (as of SW revision 102) Temperature coefficient: 400...4000ppm (variable setting range)
Set point selection/ analog input Terminals 20+23	Via the Settings menu in the controller or the electrically isolated analog input: Input resistance: 40kohms, reverse polarity-protected 0...10VDC, equivalent to 0...300°C or 0...500°C
Analog output (actual value) Terminals 20+24	0...10VDC, I _{max} = 5mA Equivalent to 0...300°C or 0...500°C Electrically isolated Accuracy: ±1% add. 50mV
Digital logic levels Terminals 3, 4, 22, 25, 26	LOW (0V): 0...2VDC HIGH (24VDC): 12...30VDC (max. current input 6mA) Electrically isolated, reverse polarity-protected
START and RELEASE (CH1) with contact Terminals 2+7 and 2+19	Switching threshold: 3.5VDC, U _{max} = 5VDC, I _{max} = 5mA
Switching output for „Output 1“/ Temp. OK" signal Terminals 20+21	U _{max} = 30VDC, I _{max} = 50mA U _{ON} < 2V (saturation voltage) Transistor conductive if the temperature is inside the tolerance band.
Alarm relay Terminals 5+6	Contact, potential-free, U _{max} = 50V (DC/AC), I _{max} = 0.2A
Relay K1 Terminals 16, 17, 18	Changeover contact, potential-free, U _{max} = 240VAC/100VDC, I _{max} = 1.5A Interference suppression with 47nF / 560ohms for each terminal
Maximum load (primary current of impulse transformer)	I _{max} = 5A (duty cycle = 100%) I _{max} = 25A (duty cycle = 20%)
Power dissipation	max. 25W
Display	LC display (green), 4 lines, 20 characters, alternatively: VF display (blue), 4 lines, 20 characters
Ambient temperature	+5...+45°C

Degree of protection	Front: IP42 (IP65 with transparent front cover, Art. No. 887000) Back: IP20
Installation	Installed in front panel cutout with (W x H) 138 ^(+0.2) x 68 ^(+0.2) mm Fastened with clips
Weight	Approx. 1.0kg (incl. connector plug-in parts)
Housing material	Black plastic, type Noryl SE1 GFN2
Connecting cable Type / cross-sections	Rigid or flexible; 0.2...2.5mm ² (AWG 24...12) Plug-in connectors  If ferrules are used, they must be crimped in accordance with DIN 46228 and IEC/EN 60947-1. This is essential for proper electrical contact in the terminals.

6 Dimensions/front panel cutout

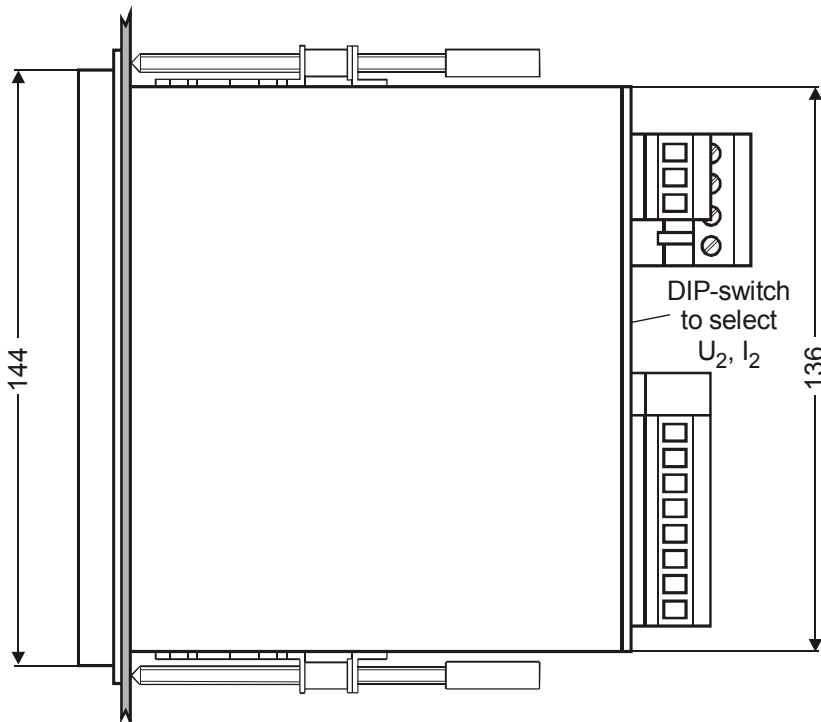
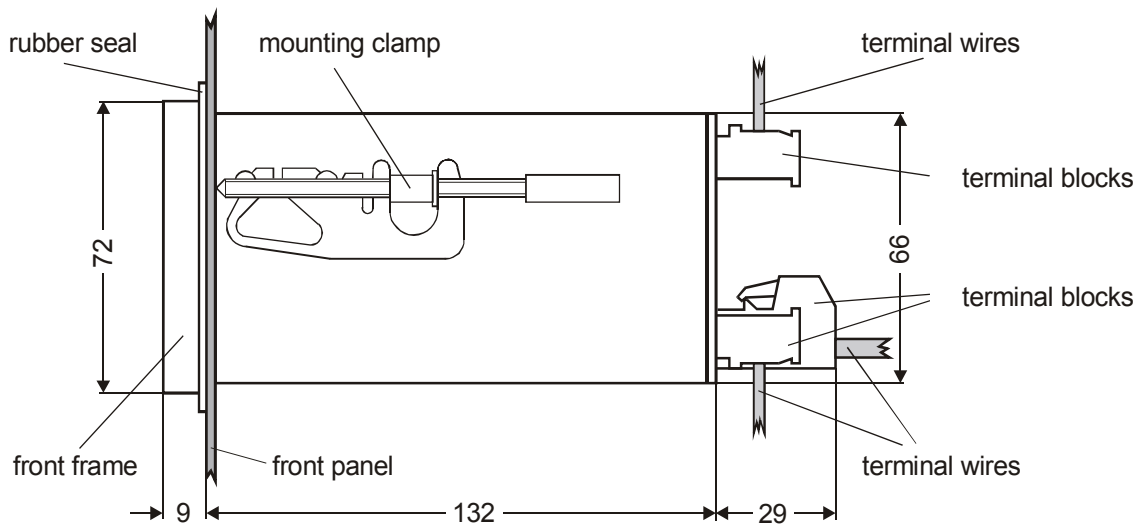
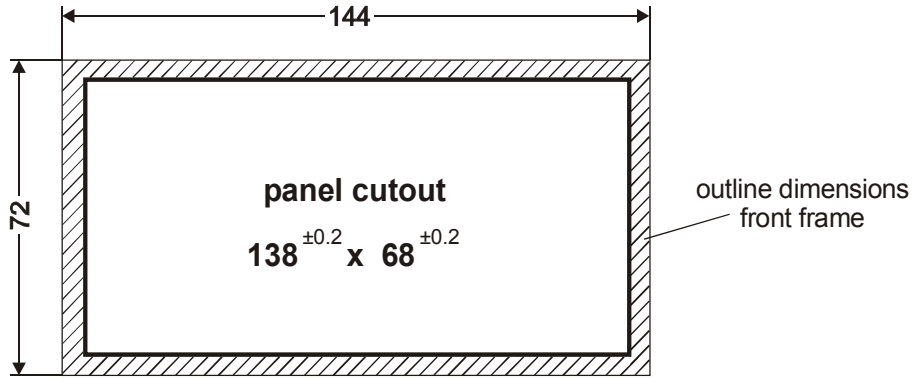

7 Installation

↳ See also Kap. 1 „Safety and warning notes“ auf Seite 3.

! Installation and startup may only be performed by technically trained, skilled persons who are familiar with the associated risks and warranty provisions.

7.1 Installation steps

1. Please refer to the safety and warning notes (↳ section 1 "Safety and warning notes" on page 3).
2. The information provided in the customized ROPEX Application Report, which is prepared by ROPEX specifically for each application, should be heeded at all times.
3. All electrical components, such as the controller, the impulse transformer and the line filter, should be installed as close as possible to the UPT sealing bar(s) in order to avoid long wires.
4. Connect the voltage measurement cable U_R directly to the UPT sealing bar and lay it twisted to the controller (UML-1 voltage measurement cable ↳ section 4 "Accessories and modifications" on page 7).
5. Ensure an adequate cable cross-section for the primary and secondary circuits (↳ Application Report).
6. Use only ROPEX impulse transformers or transformers approved by ROPEX. Please note the power, the duty cycle and the primary and secondary

voltages (↳ Application Report).

7.2 Installation procedure

Proceed as follows to install the CIRUS temperature controller UPT-640 (as of SW 100):

1. Switch off the line voltage and verify the safe isolation from the supply.
2. The supply voltage specified on the nameplate of the CIRUS temperature controller must be identical to the line voltage that is present in the plant or machine. The line frequency is automatically detected by the temperature controller in the range from 47Hz to 63Hz.
3. Install the CIRUS temperature controller in the front panel cutout. It is fastened by means of two clips which snap onto the side of the controller housing.
4. Wire the system in accordance with the instructions in section 7.3 "Power supply" on page 13, section 7.6 "Wiring diagram (standard)" on page 15 and the ROPEX Application Report. The information provided in section 7.1 "Installation steps" on page 12 must be heeded additionally.

! Check the tightness of all the system connections, including the terminals for the winding wires on the impulse transformer.

5. Make sure that the wiring conforms to the relevant national and international installation regulations.

7.3 Power supply

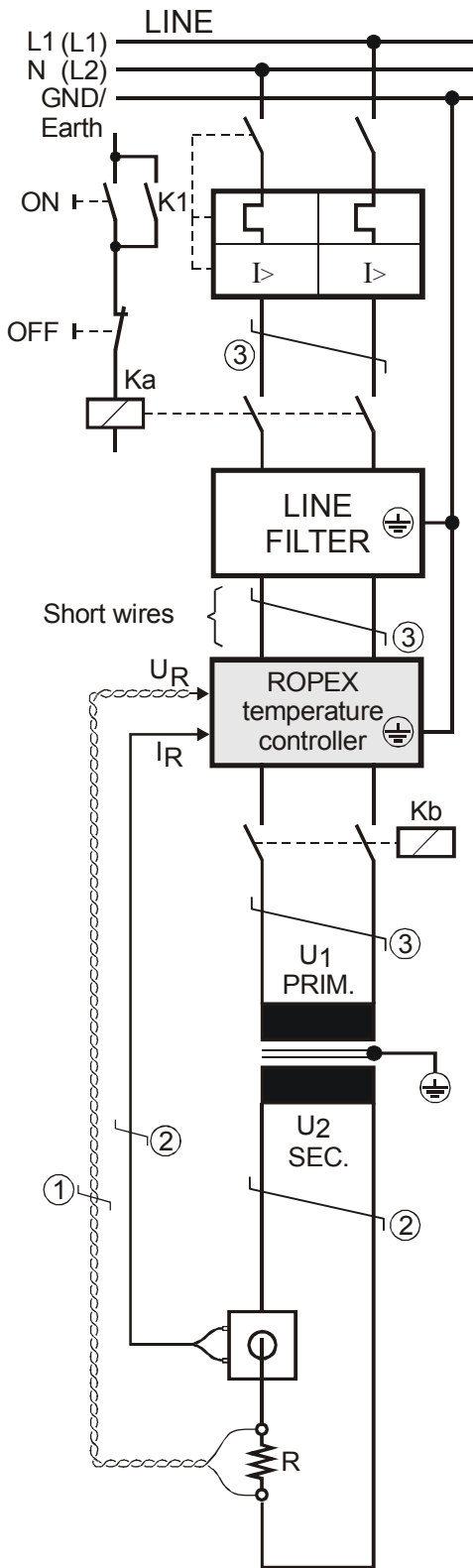

Line

230VAC, 400VAC
50/60Hz

Circuit breaker

Double-pole, C characteristic
(☞ ROPEX Application Report)

- ⚠ Short-circuit protection only.
- ⚠ CIRUS temperature controller not protected.

Relay Ka

For "HEAT ON - OFF" function (all-pole) or "EMERGENCY STOP".

Line filter

The filter type and size must be determined according to the load, the transformer and the machine wiring (☞ ROPEX Application Report).

- ⚠ Do not run the filter supply wires (line side) parallel to the filter output wires (load side).

CIRUS temperature controller belonging to the 6xx Series.

Relay Kb

Load break (all-pole), e.g. in combination with the alarm output of the temperature controller.

- ⚠ When using a series resistor RV-....-1 the relay Kb shall be installed.

Impulse Transformer

Designed according to VDE 0570/EN 61558 (isolating transformer with reinforced insulation). Connect core to ground.

- ⚠ Use transformers with a one section bobbin. The power, duty cycle and voltage values must be determined individually according to the application (☞ ROPEX Application Report and "Accessories" leaflet for impulse transformers).

Wiring

The wire cross-sections depend on the application (☞ ROPEX Application Report).

Guide values:

- Primary circuit: min. 1.5mm², max. 2.5mm²
- Secondary circuit: min. 4.0mm², max. 25mm²

- ① These wires must always be twisted (>20/m)
- ② These wires must be twisted (>20/m) if several control loops are laid together ("crosstalk").
- ③ Twisting (>20/m) is recommended to improve EMC.

7.4 Line filter

To comply with EMC directives – corresponding to EN 50081-1 and EN 50082-2 – RESISTRON control loops must be operated with line filters.

These filters damp the reaction of the phase-angle control on the line and protect the controller against line disturbances.

⚠ The use of a suitable line filter is part of the standards conformity and a prerequisite of the CE mark.

installed and wired correctly, they guarantee compliance with the EMC limit values.

You can find the exact specification of the line filter in the ROPEX Application Report calculated for your particular heatsealing application.

For more technical information: ↪ "Line filter" documentation.

⚠ It is permissible to supply several CIRUS control loops with a single line filter, providing the total current does not exceed the maximum current of the filter.

ROPEX line filters are specially optimized for use in RESISTRON control loops. Providing that they are

The wiring instructions contained in section 7.3 "Power supply" on page 13 must be observed.

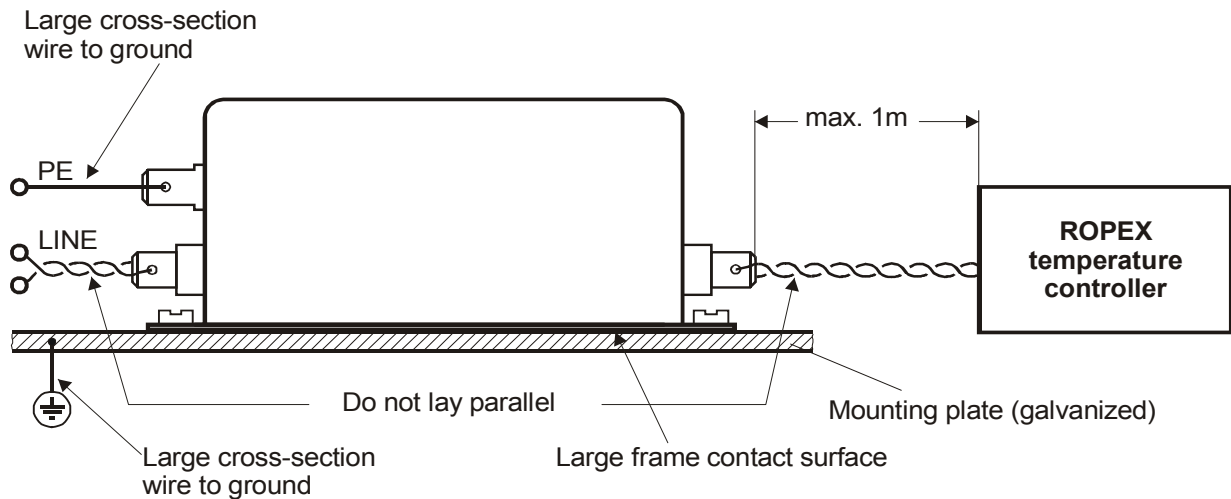

7.5 Current transformer PEX-W3

The PEX-W3 current transformer supplied with the RESISTRON temperature controller is an integral part

of the control system. The current transformer may only be operated if it is connected to the temperature controller correctly (↪ section 7.3 "Power supply" on page 13).

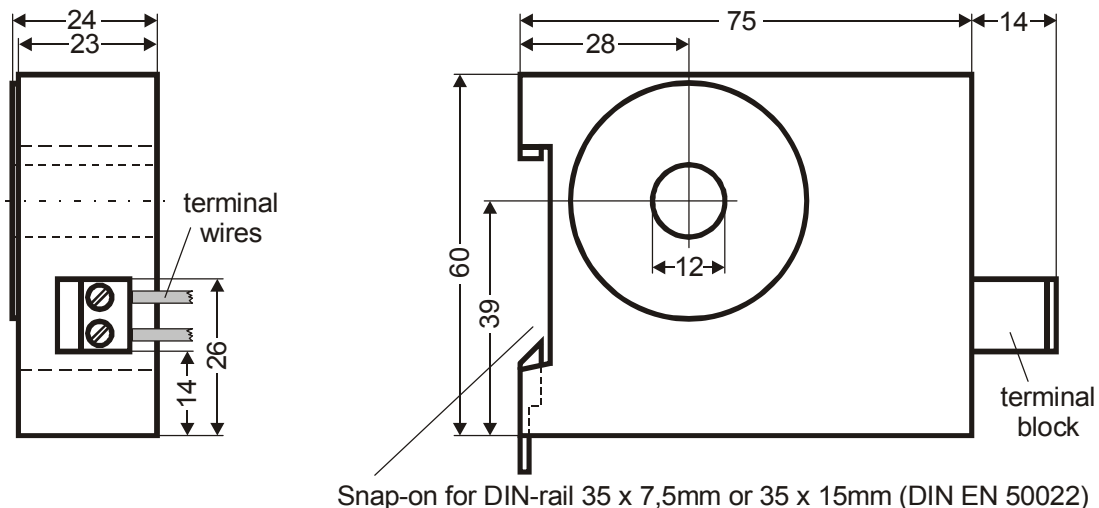

7.6 Wiring diagram (standard)

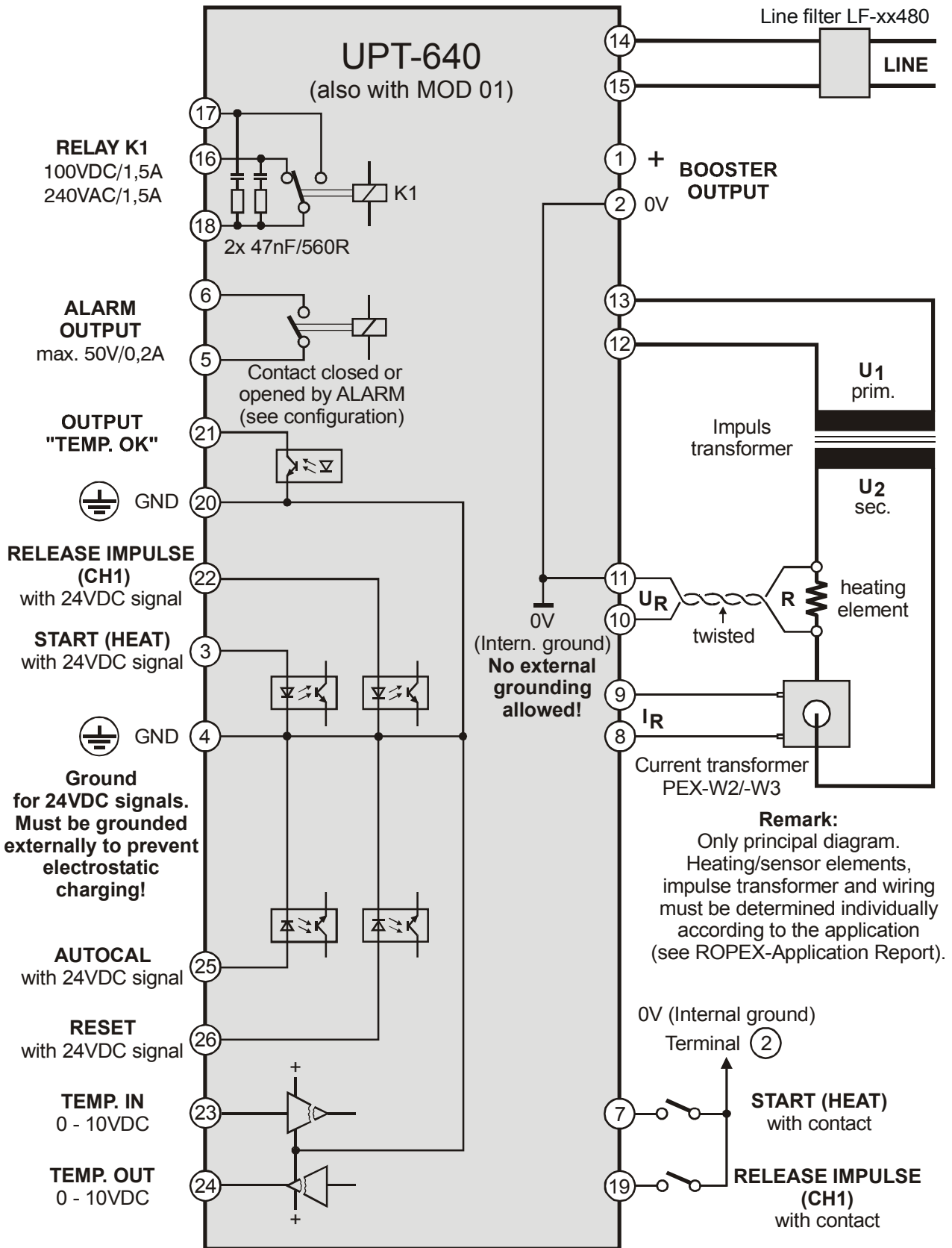

7.7 Wiring diagram with booster connection

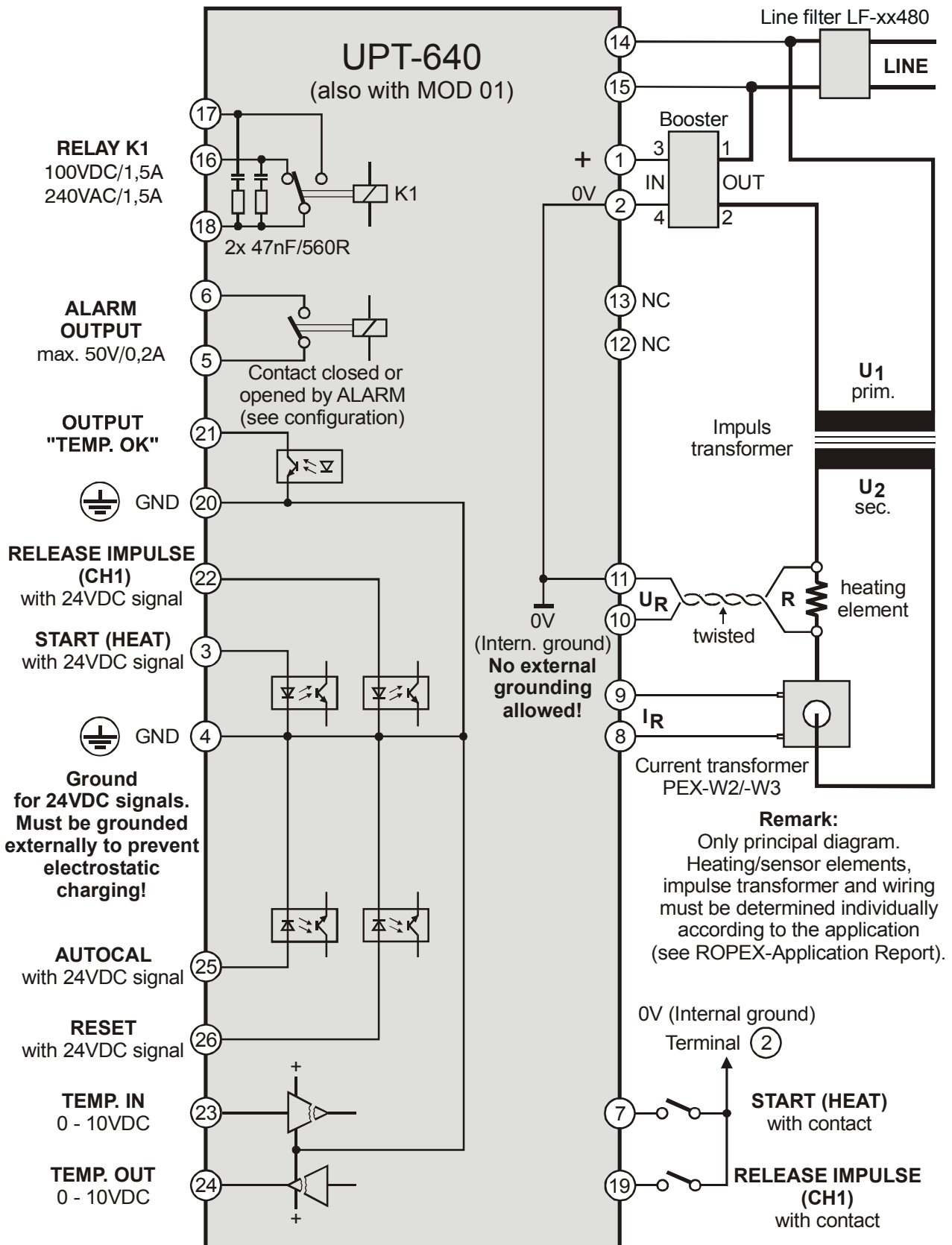

8 Startup and operation

8.1 Front view of the controller



8.2 Rear view of the controller

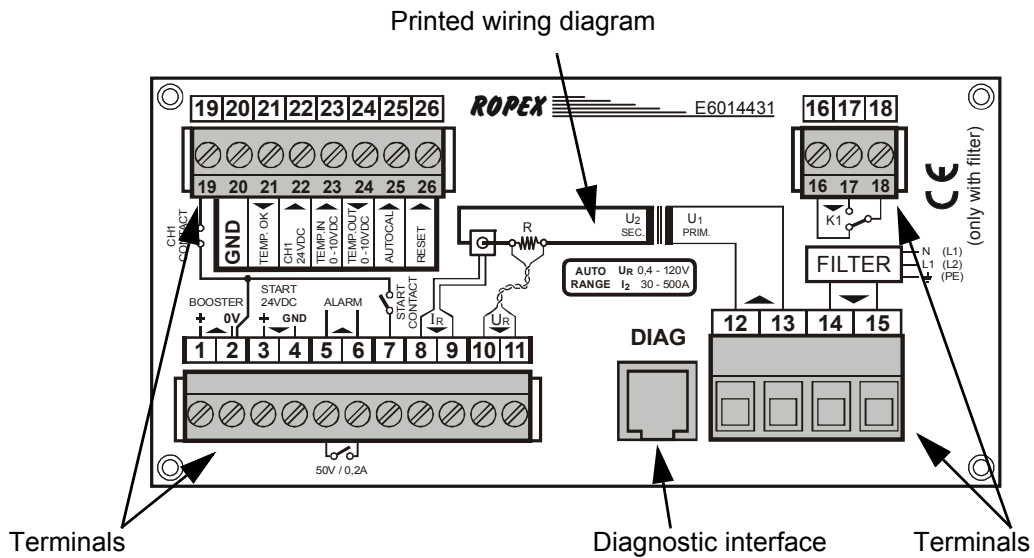

8.3 Controller configuration

The possible controller configurations are explained in the following sections. Proceed as described in Kap. 8.5.1 „Initial startup“ auf Seite 21 to start up the controller for the first time.

8.3.1 Automatic configuration (AUTORANGE) for secondary voltage and current

The secondary voltage and current ranges are automatically configured by the automatic calibration function (AUTOCAL). The voltage is configured in the range from 0.4VAC to 120VAC and the current in the range from 30A to 500A. If the voltage and/or the current is outside the permissible range, a detailed error message appears on the controller (↪ s. section 9.27 "Fault areas and causes" on page 50).

If the secondary current I_2 is less than 30A, the PEX-W2/W3 current transformer must have two turns (↪ ROPEX Application Report).



8.3.2 Setting the language

The menu language can be changed on the controller without interrupting operation. It is set with step 201 in the Configuration menu:

The following settings are possible:

English, German, Italian, French, Spanish, Dutch, Danish, Finnish, Swedish, Greek, Turkish, Portuguese.

 **The language which is selected in this menu remains set even if the factory settings are restored (step 202 in the Configuration menu).**

8.3.3 Restoring the factory settings

The internal controller settings can be reset to the factory settings with step 202 in the Configuration menu. Only the language setting (step 201 in the Configuration menu) remains unchanged.

Please refer to section 10 "Factory settings" on page 51 for more information about the factory settings.

 **If the controller settings are unknown when it is started up for the first time, the factory settings must be restored in order to prevent malfunctions.**

8.3.4 Configuration of the alloy (Temperature coefficient)

The heatsealing band alloy (and the temperature coefficient respectively) can be set with steps 203 and 204 in the Configuration menu.

In step 203 predefined values for the alloy (and the temperature coefficient respectively) are available:

1. **Temperature coefficient 1700ppm**
(e.g. ROPEX CIRUS system)
2. **Temperature coefficient „variable“**
Further settings in step 204.

In step 204 the temperature coefficient can be set in a range of 400...4000 ppm individually for the used heatsealing band then.

 **Step 204 in the Configuration menu is available when step 203 is set to "variable" only.**

8.3.5 Configuration of the temperature range

The temperature range can be set with steps 205 in the Configuration menu.

The setting can be 200°C, 300°C (Factory setting), 400°C or 500°C.

 **The temperature ranges with 400°C and 500°C shall be used after confirmation of ROPEX only. The lifetime of the UPT heating elements is significantly reduced when using higher sealing temperatures.**

8.3.6 Configuration of the timer function

 **The necessary controller settings are explained in the detailed functional descriptions in section 9.4 "Menu structure" on page 27 and section 9.23 "Time control (timer function)" on page 38. They are only allowed to be entered by technically trained persons.**

The timer function is activated with step 209 in the Configuration menu.

8.3.7 Relay K1 (without time control)

The function of relay K1 is specified with step 212 in the Configuration menu. The following settings are possible when time control is deactivated:

1. **"Off" (Factory setting)**
Relay K1 has no function
2. **"Active if Tact = Tset"**
Relay K1 is activated if the actual value is inside the specified temperature tolerance band (steps 207, 208). If the actual temperature is outside the tolerance band, relay K1 is deactivated (see graph below).

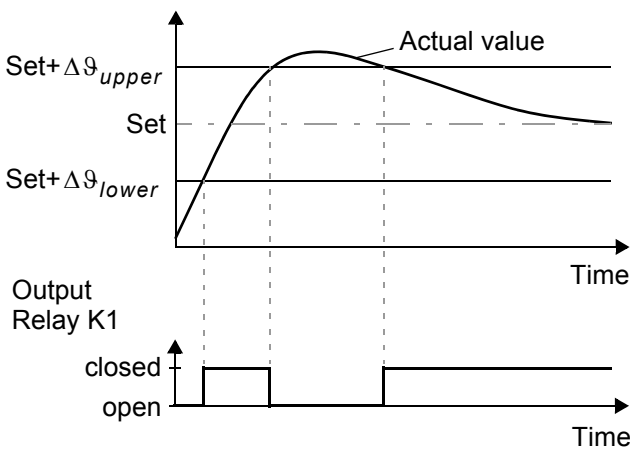

3. **"Active if Tact = Tset", with latch function**
Relay K1 is closed if the actual value is inside the specified temperature tolerance band (steps 207, 208). If the actual temperature leaves the tolerance band once while the "START" signal is active, relay K1 is opened. The relay is not closed again until the next "START" signal is activated. The switching state of relay K1 can thus also be interrogated by the higher-level PLC after a heatsealing process (latch function, see graph below).

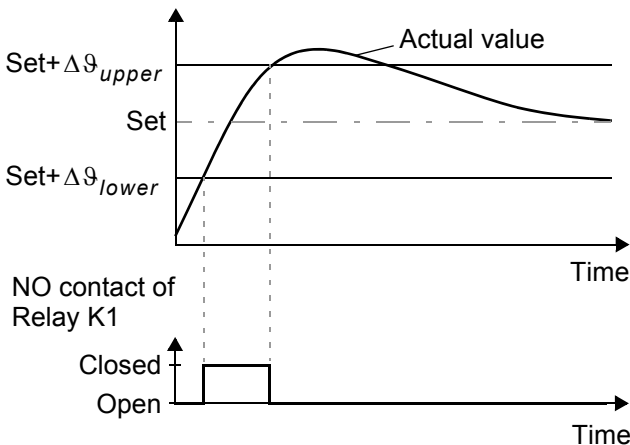

Other settings are available in this menu when time control (timer function) is active. They are described in section 9.23.6 "Relay K1 (with time control)" on page 41.

8.3.8 "Output 1"/ „Temperature OK“ signal (without time control)

! On controllers up to software revision 022, the switching output at terminals 20+21 was called "Temperature OK". The more general name "Output 1" is used as of software revision 100 because this output now also supports other functions.

The "Output 1" signal is available at terminals 20+21 as a digital control signal.

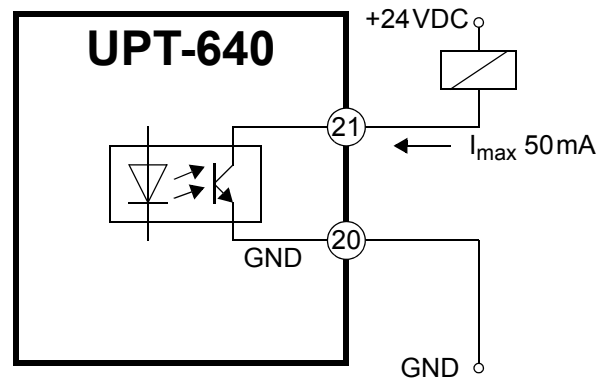

If time control (timer function) is deactivated, the same configuration options are available for "Output 1" as for relay K1 (↪ section 8.3.7 "Relay K1 (without time control)" on page 19). The options for "Output 1" are specified with step 222 in the Configuration menu as follows:

1. **"Off"**
"Output 1" has no function
2. **"Active if Tact = Tset"**
Output 1 is conductive if the actual value is inside the specified temperature tolerance band (steps 207, 208). If the actual temperature is outside the tolerance band, "Output 1" is not conductive. This function is the same as for the "Temperature OK" signal up to software revision 022.

3. "Active if Tact = Tset", with latch function (factory setting)

"Output 1" is conductive if the actual value is inside the specified temperature tolerance band (steps 207, 208). If the actual temperature leaves the tolerance band once while the "START" signal is active, "Output 1" is no longer conductive. "Output 1" does not become conductive again until the next "START" signal is activated and can thus also be interrogated by the higher-level PLC after a heatsealing process.

Other settings are available in this menu when time control (timer function) is active. They are described in section 9.23.7 "Output 1"/ „Temperature OK" signal (with time control)" on page 43.

8.3.9 Temperature diagnosis

The temperature diagnosis function can be activated by means of step 217 in the Configuration menu. The UPT-640 (as of SW 100) then checks whether the ACTUAL temperature is inside a specifiable tolerance band ("OK" window) on either side of the SET temperature. The lower ($\Delta\vartheta_{lower}$) and upper ($\Delta\vartheta_{upper}$) limits of the tolerance band can be changed independently of one another by means of steps 207 + 208 (factory setting: -10K or +10K).

If the ACTUAL temperature is inside the specified tolerance band when the "START" signal is activated, the temperature diagnosis is also activated. If the ACTUAL temperature leaves the tolerance band, the corresponding error code (307, 308) is indicated and the fault output is switched (↪ section 9.27 "Fault areas and causes" on page 50). If a heatsealing cycle is in progress, it is immediately interrupted.

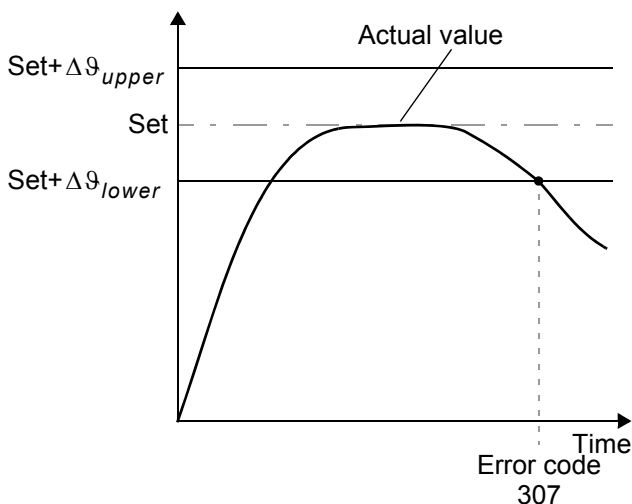

If the temperature diagnosis is not activated by the time the "START" signal is deactivated (i.e. if the ACTUAL temperature does not exceed the upper or lower tolerance band limit), the corresponding error code (309, 310) is indicated and the fault relay is switched. If the temperature diagnosis function is activated, an additional delay time of 0 to 9.9s can be parameterized for the temperature timeout with step 218 in the Configuration menu. The first time the lower tolerance band limit is exceeded, the temperature diagnosis is not activated until the parameterized delay time has elapsed. The temperature diagnosis function can thus be explicitly deactivated, e.g. if the temperature drops temporarily owing to the closure of the sealing jaws.

8.3.10 Heatup timeout

The heatup timeout can be parameterized with step 219 in the Configuration menu ("0" = OFF). This timeout starts when the START signal is activated. The UPT-640 (as of SW 100) then monitors the time required for the ACTUAL temperature to reach 95% of the SET temperature. If this time is longer than the parameterized time, the corresponding error code (304) is indicated and the fault relay is switched (↪ section 9.27 "Fault areas and causes" on page 50).

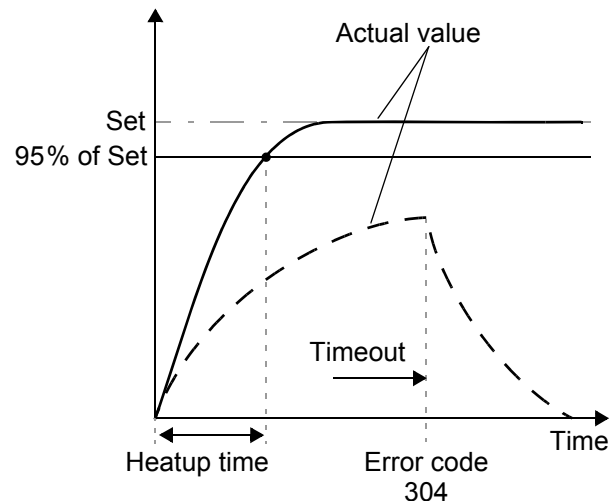

8.3.11 Configuration of the alarm relay

The alarm relay is set with step 215 in the Configuration menu.

There are two possible settings:

1. **"Normal" (Factory setting)**
Alarm relay contact closed by a fault
2. **"Inverse"**
Alarm relay contact opened by a fault

8.4 Heating element

8.4.1 General

The heating element is a key component in the control loop, since it is both a heating element and a sensor. The geometry of the heating element is too complex to be discussed at length here. We shall therefore only refer to a few of the most important physical and electrical properties:

The measuring principle applied for this system necessitates a heating element alloy with a suitable temperature coefficient TCR, i.e. one whose resistance increases as the temperature rises.

Too low a TCR leads to oscillation or uncontrolled heating.

When heatsealing bands with a higher TCR are used, the controller must be calibrated for this.

! The base resistance of the heating elements rises continuously during operation (construction-conditioned). Due to this the AUTOCAL function must be executed every 100.000 sealing cycles for preventing measurement failures of the ACTUAL temperature.

8.4.2 Replacing the heating element

All power supply leads must be disconnected from the CIRUS temperature controller in order to replace the heating element.

! The heating element must be replaced in accordance with the instructions provided by the manufacturer.

Each time the heating element is replaced, the zero point must be calibrated with the AUTOCAL function (↪ section 9.8 "Automatic zero calibration (AUTOCAL)" on page 32) while the element band is still cold. The correction factor Co (↪ section 9.11 "Correction factor Co" on page 34) must be adjusted too. With this procedure the production-related resistance tolerances of the heating element will be compensated.

8.5 Startup procedure

Please also refer to Kap. 1 „Safety and warning notes“ auf Seite 3 and Kap. 2 „Application“ auf Seite 4.

! Installation and startup may only be performed by technically trained, skilled per-

sons who are familiar with the associated risks and warranty provisions.

8.5.1 Initial startup

Prerequisites: The controller must be correctly installed and connected (↪ Kap. 7 „Installation“ auf Seite 12).

The possible settings are described in detail in chap. 8.3 „Controller configuration“, page 18 and chap. 9 „Controller functions“, page 23.

The essential controller configurations are described below:

1. Switch off the line voltage and verify that all circuits are deenergized.
2. The supply voltage specified on the nameplate of the controller must be identical to the line voltage that is present in the plant or machine. The line frequency is automatically detected by the temperature controller in the range from 47 to 63Hz.
3. Make sure that a START signal is not present.
4. Switch on the line voltage.
5. A power-up message appears on the display for approximately 2 seconds when the controller is switched on to indicate that it has been started up correctly.
6. One of the following states then appears:

DISPLAY	ACTION
Main menu	Go to 7
Error message with error codes 104...106, 111...113, 211	Go to 7
Error message with error codes 101...103, 107, 108, 201...203, 801, 9xx	Fault diagnosis (↪ 9.27)

7. Set the controller configuration as described in Kap. 8.3 „Controller configuration“ auf Seite 18. The following settings are always required:

Setting	Step in Configuration menu
Language	201
Restore factory settings	202
Temperature range and heatsealing band alloy	203, 204, 205

8. Activate the AUTOCAL function while the heatsealing band is still cold (with step 7 in the Settings

menu or by means of the "AUTOCAL" signal, terminals 20+25). The progress of the calibration process is indicated by a counter on the display (approx. 10...15s). A voltage of app. 0VDC appears at the same time at the actual value output (terminals 20+24). If an ATR-x is connected, it indicates 0...3°C.

When the zero point has been calibrated, the display is reset to the home position and 20°C is indicated as the actual value. A voltage of 0.66VDC (for the 300°C range) or 0.4VDC (for the 400°C range, equivalent to 20°C, appears at the actual value output. If an ATR-x is connected, it must be set to "Z" (20°C).

If the zero has not been calibrated successfully, an error message indicates error codes 104...106, 211. In this case the controller configuration is incorrect (↪ Kap. 8.3 „Controller configuration“ auf Seite 18 and ROPEX Application Report). Repeat the zero point calibration after the controller has been configured correctly.

9. When the zero point has been calibrated successfully, the main menu appears on the display again. Then specify a defined temperature (heatsealing temperature) with step 1 in the Settings menu (or apply a 0...10VDC voltage to the analog input, terminals 20+23) and activate the "START" signal (HEAT). Alternatively, a heatsealing process can be started by pressing the "HAND" key (display in home position). The indication of the ACTUAL tem-

perature on the display (digital value and dynamic bar) permits the heating and control process to be monitored.

The controller is functioning correctly if the temperature indicated on the display has a continuous curve, in other words it must not jump abruptly, fluctuate or deviate temporarily in the wrong direction. This kind of behavior would indicate that the U_R measuring wire has been laid incorrectly.

If an error code is displayed, please proceed as described in section 9.27 "Fault areas and causes" on page 50.

10. Optimizing the heating up and temperature control function by adjusting the correction factor C_o in menu step 110 (↪ section 9.11 "Correction factor C_o " on page 34). With this procedure the production-related resistance tolerances of the heating element will be compensated.

 **If the heatsealing temperature is selected via the analog input at terminals 20+23, the specified voltage value must be checked with a voltmeter before the heatsealing process begins, in order to prevent incorrect settings or excessively high heatsealing temperatures.**

The controller is now ready

9 Controller functions

See also Kap. 7.6 „Wiring diagram (standard)“ auf Seite 15.

9.1 Indicators and controls

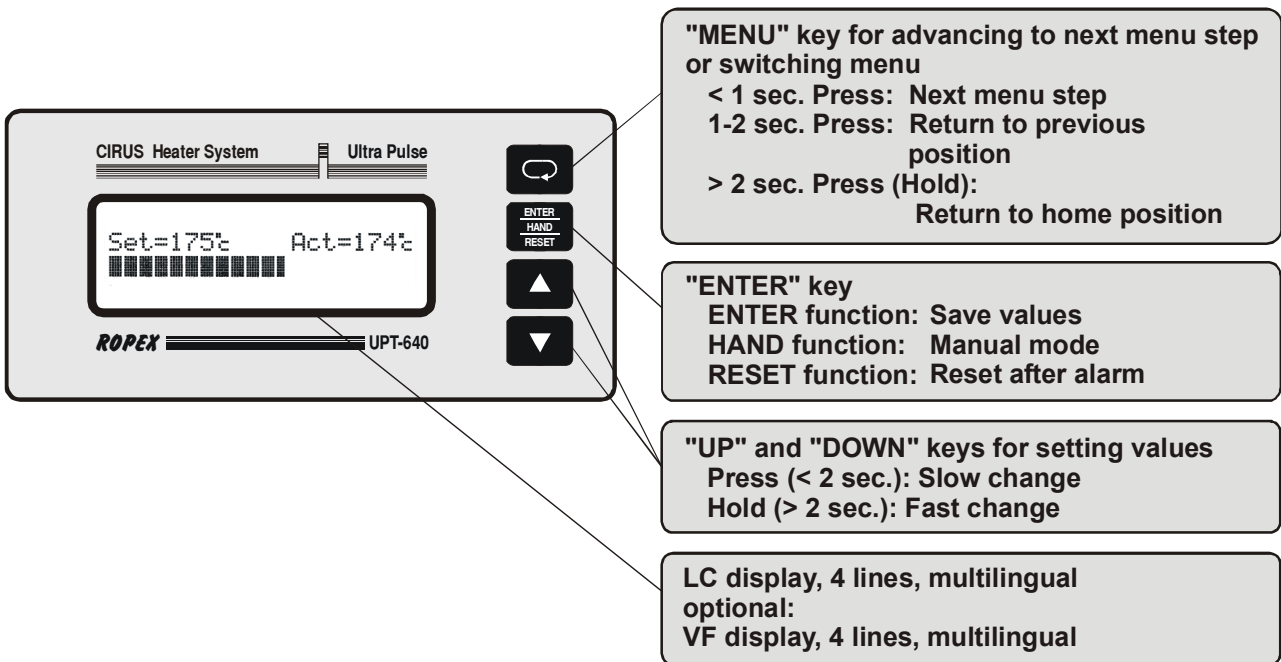

9.2 Display

This message also includes details of the software version.

9.2.1 Power-up message

A power-up message appears on the display for approximately 2 seconds when the controller is switched on.

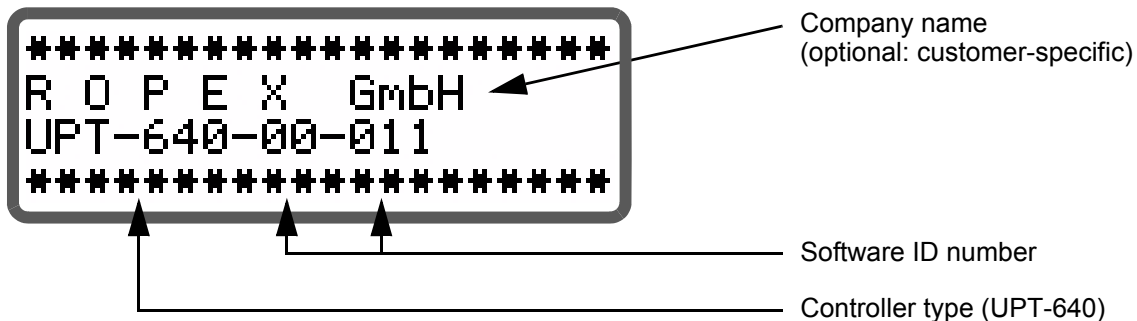

9.2.2 Display in home position

If no settings are entered on the controller and no error message are present, the display is in the home position, in other words it indicates the SET temperature as

a digital value and the ACTUAL temperature as a digital value and a dynamic bar. If time control (timer function) is active, the time control settings are also displayed.

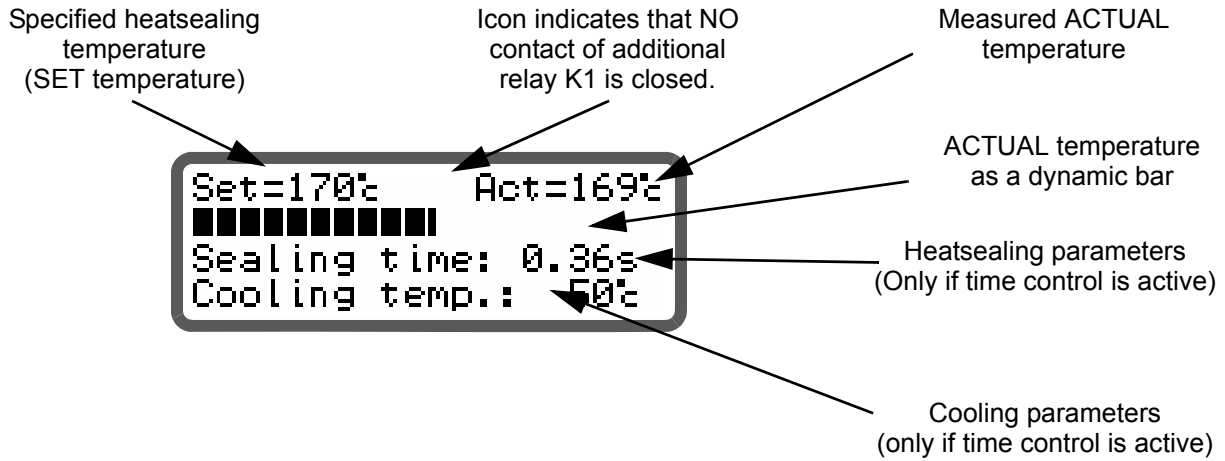

9.2.3 Settings/Configuration menus

The required parameters are set on two menu levels: the Settings (control) menu and the Configuration menu (↳ Kap. 9.4 „Menu structure“ auf Seite 27).

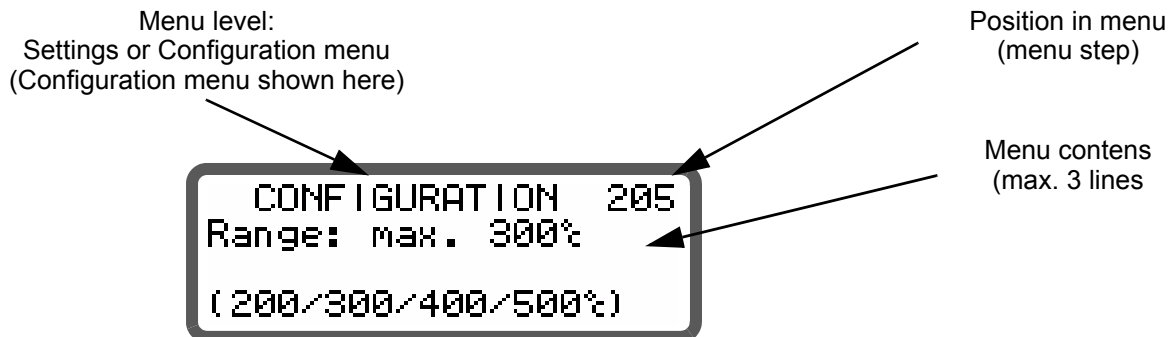

9.2.4 Error messages

The fault diagnosis function of the controller is always active. If a fault is detected, it is indicated on the display

immediately in the form of an error message (↳ Kap. 9.25 „System monitoring/alarm output“ auf Seite 46).

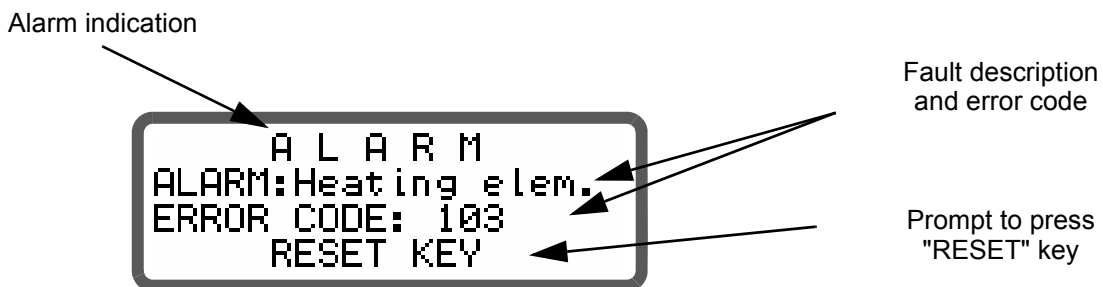

9.3 Navigation in the menus

9.3.1 Navigation in menus without a fault

A "MENU" key is provided for navigating through the various menu steps and levels. By pressing this key briefly (<1s) at any time, you can jump to the next menu step. You can also jump to the previous menu step by pressing the "MENU" key for 1-2s. By pressing the key for longer (>2s), you can return to the home position from anywhere in the menu structure, providing a con-

troller alarm is not active. In this case, the Alarm menu is opened instead.

If the display is in the home position or an alarm is indicated and you press the "MENU" key for longer than 2s, you are taken directly to the configuration level (starting at step 201).

In addition, you always return to the home position if you do not press any keys for a period of 30s. There is no automatic return after 30s from "AUTOCAL" or "Alarm".

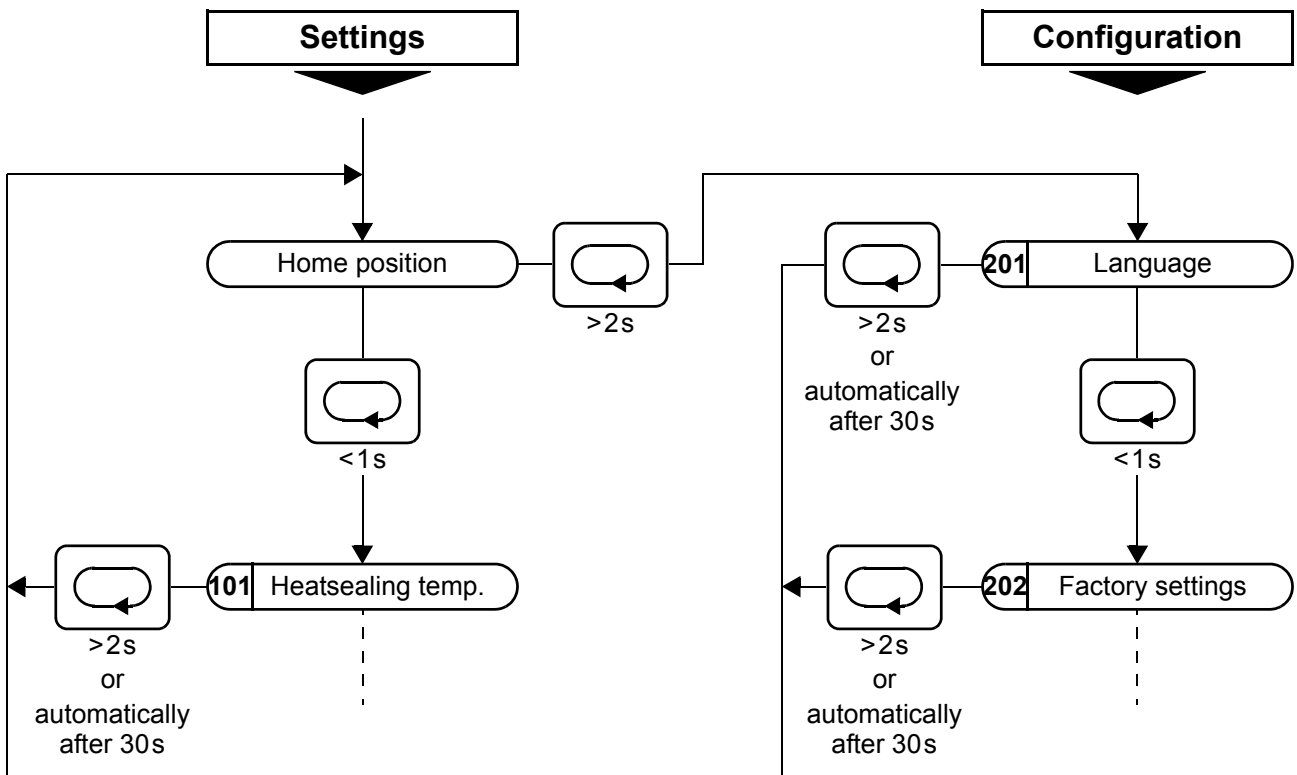

9.3.2 Navigation in menus with a fault

If an alarm is signaled, the controller switches to the Alarm menu. Some faults can be acknowledged by pressing the "RESET" key (↵ Kap. 9.25 „System monitoring/alarm output“ auf Seite 46). In this case, the controller switches back to the home position.

If the fault can be rectified by executing the AUTOCAL function, you can select the "AUTOCAL" menu step directly by briefly pressing the "MENU" key (<2s). You

can then activate the "AUTOCAL" function by pressing the "ENTER" key (↵ section 9.8 "Automatic zero calibration (AUTOCAL)" on page 32).

If you press the "MENU" key for longer than 2s in the Alarm menu, you are taken directly to the configuration level (starting at step 201). You can return from the Configuration menu to the Alarm menu either by pressing the "MENU" key for longer than 2s or by not pressing any keys for 30s.

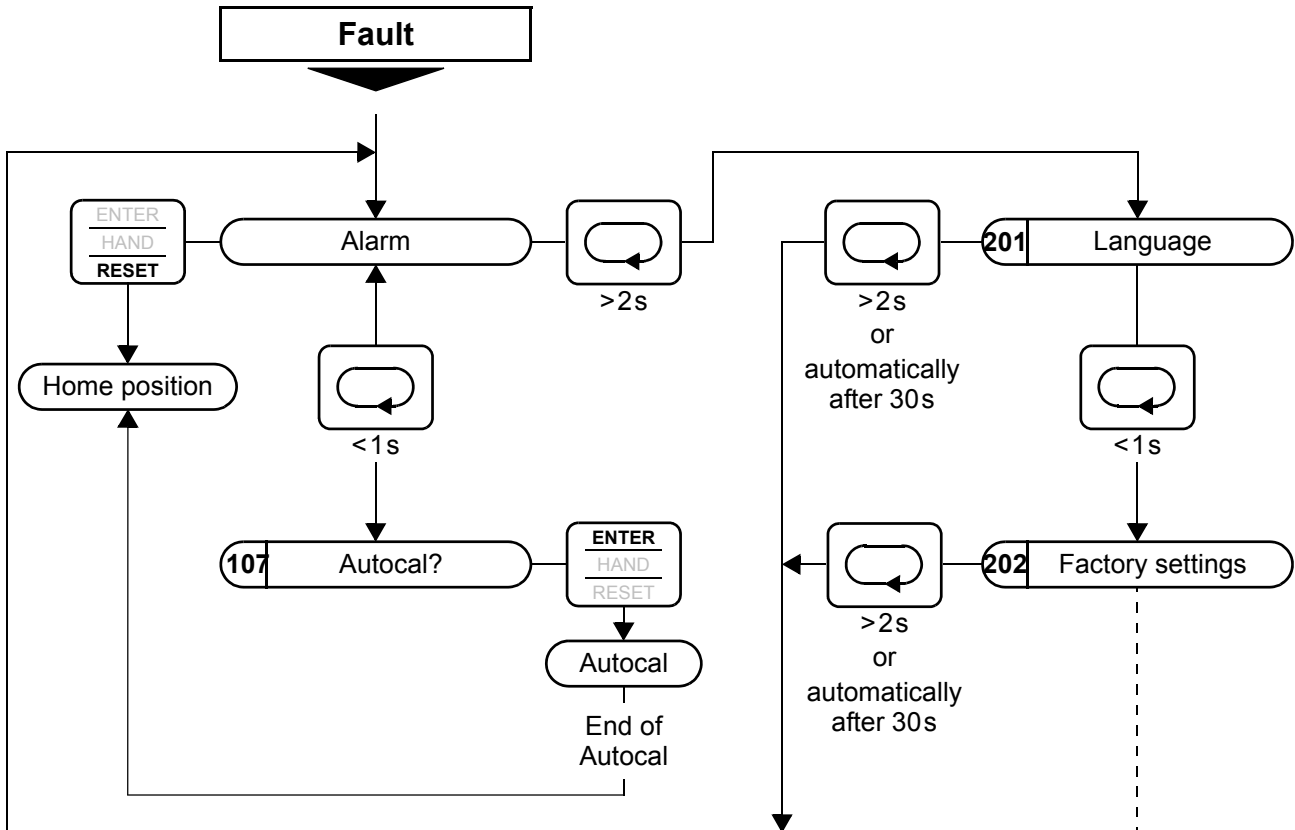

9.4 Menu structure

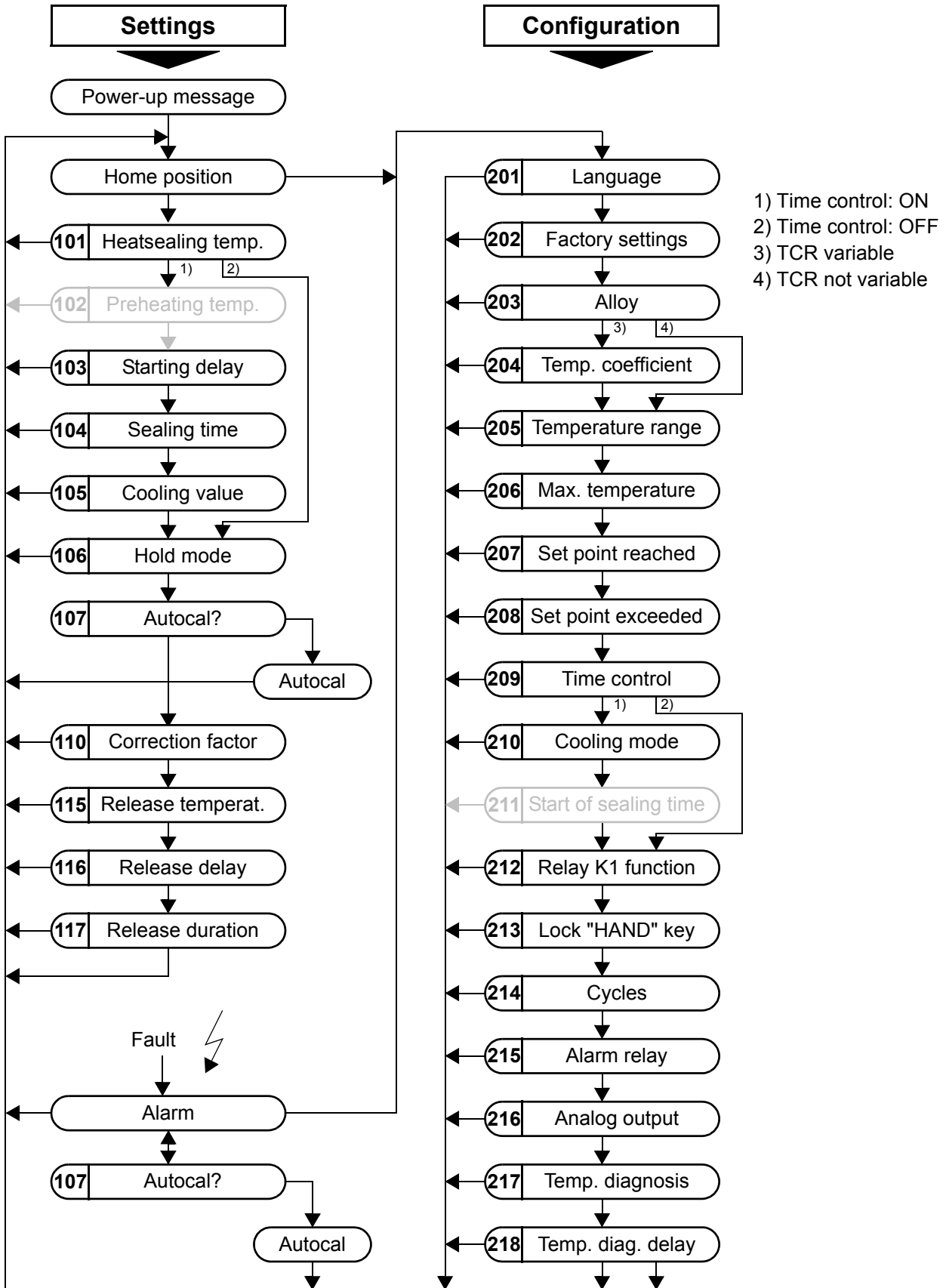

Continued on next page

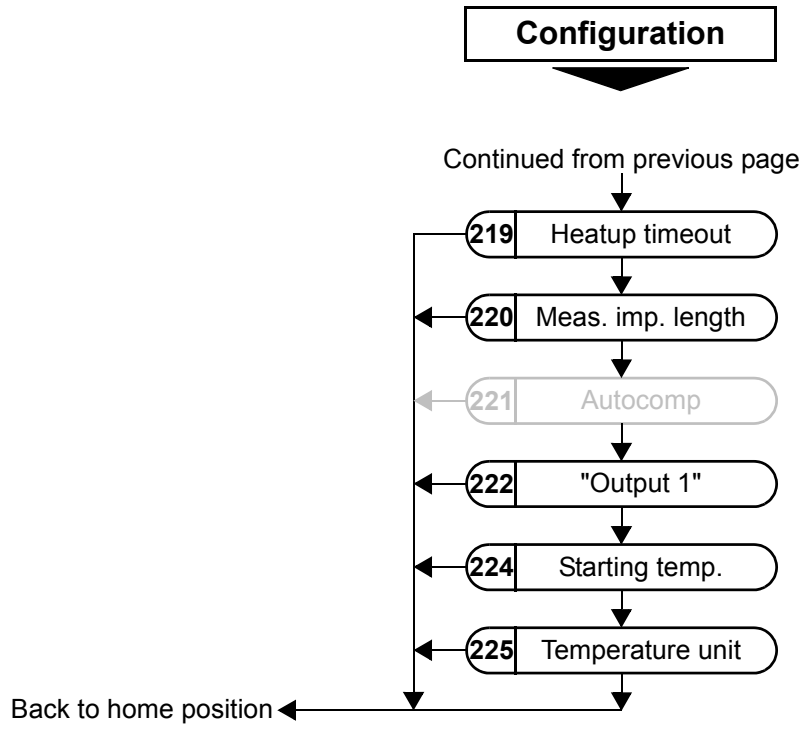

9.5 Two-digit numbering system up to software revision 022

A system of one and two-digit numbers was used for the Settings and Configuration menus up to software

revision 022. Three-digit numbers were introduced in software revision 100 to improve the clarity of the menu structure.

The table below compares the two numbering systems:

Menu	Menu steps	Numbering up to software revision 022	Numbering as of software revision 100
Settings menu	Heatsealing temperature	2	101
	Starting delay	3	103
	Heatsealing time	3	104
	Cooling value	4	105
	Hold mode	5	106
	AUTOCAL	1	107
	Correction factor Co	6	110
	Release temperature	10	115
	Release delay	11	116
	Release duration	12	117
Configuration menu	Language	30	201
	Factory settings	31	202
	Alloy / TCR	32	203, 204
	Maximim temperature	33	206
	Set point reached	35	207
	Set point exceeded	36	208
	Time control	37	209
	Cooling mode	38	210
	Relay K1 function	39	212
	Cycles	42	214
	Alarm relay	43	215
	Analog output	34	216
	Starting temperature	40	224
No longer available menus	Cycle configuration	20	---
	Hand impulse	21	---

 All numbers or menu steps not listed above are only available as of software revision 100 and are described in chap. 8 „Startup and opera-

tion“, page 17 (and section 9.4 "Menu structure" on page 27 respectively).

9.6 Temperature setting (set point selection)

The heatsealing temperature can be set on the UPT-640 (as of SW 100) controller in three ways:

- By means of the setting in menu step 101.
- By applying a 0...10VDC voltage to the analog input at terminals 20+23.

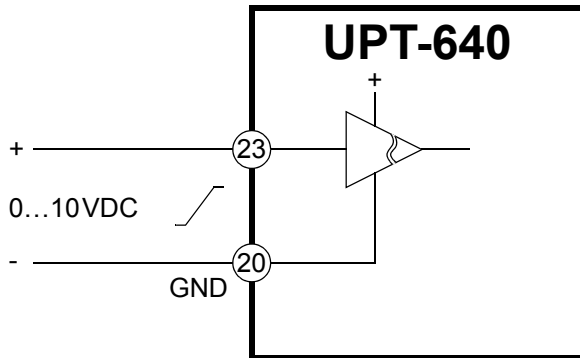

The relationship between the applied voltage and the SET temperature is linear.

Voltage values:

0VDC → 0°C

10VDC → 300°C or 500°C (depending on the controller configuration).

Please refer to Kap. 9.7 „Temperature indication/actual value output“ auf Seite 31 for a circuit diagram.

If the heatsealing temperature is to be determined by a voltage at the analog input at terminals 20+23, it must be set to 0°C with menu step 101.

! If an external heatsealing temperature (analog input, terminals 20+23) and an internal heatsealing temperature (step 101) are specified simultaneously, the higher of the two temperatures is used and indicated in the home position.

! The maximum value of the setting range is limited either by the maximum value specified with step 206 in the Configuration menu or by the heatsealing band type/temperature range set with step 205.

The set point that is selected for the heatsealing temperature must be greater than 40°C. If not, the heatse-

aling band will not be heated up when the "START" signal is activated or the "HAND" key is pressed. The set heatsealing temperature is displayed in the main menu once it has been entered.

! If the heatsealing temperature is specified via the analog input at terminals 20+23, the external voltage must be activated at least 100ms before the heatsealing process starts. If not, the heatsealing temperature will not reach the required value.

- By connecting a 2kohm potentiometer (e.g. PD-3 or PD-5) to terminals 20, 23 and 24:

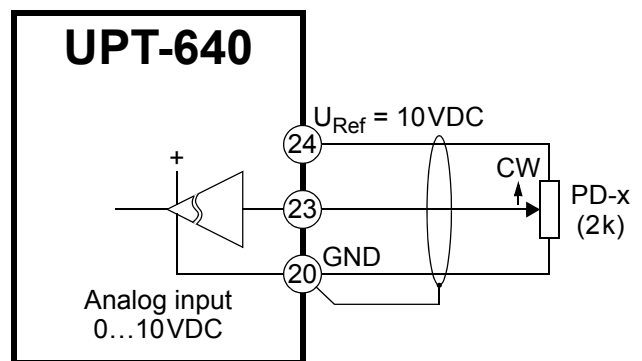

Potentiometer with digital dial PD-x

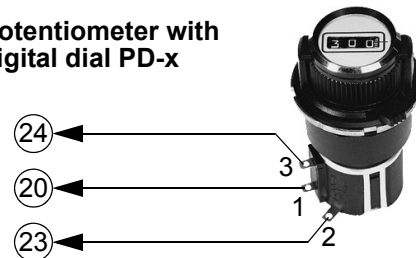

The controller is configured for this purpose so that a fixed 10VDC reference voltage is available at the analog output at terminal 24 (↪ menu step 216, section 9.7 "Temperature indication/actual value output" on page 31).

This voltage is divided by the PD-x set point potentiometer and supplied to the analog input at terminal 23. You can then specify the set temperature in °C in the digital window of the potentiometer.

Once again, the set temperature must be set to zero in step 101.

9.7 Temperature indication/actual value output

If the display is in the home position, the ACTUAL temperature is indicated there as a digital value and as a dynamic bar.

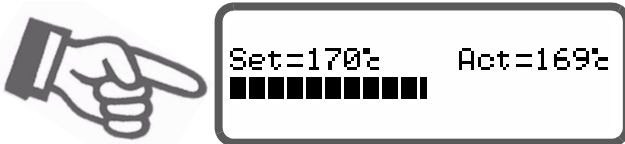

The heating and control process can thus be monitored at any time.

In addition, the UPT-640 (as of SW 100) controller outputs an electrically isolated, analog 0...10VDC signal, which is proportional to the real ACTUAL temperature, at terminals 20+24.

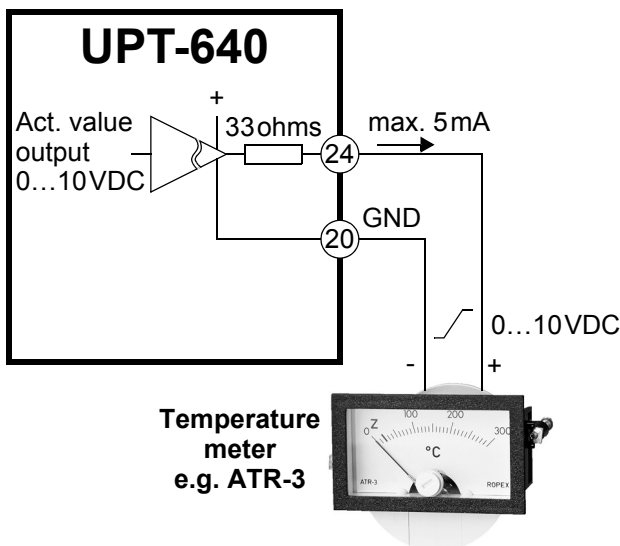

Voltage values:
 0VDC → 0°C
 10VDC → 300°C or 500°C (depending on the controller configuration).

The relationship between the change in the output voltage and the ACTUAL temperature is linear.

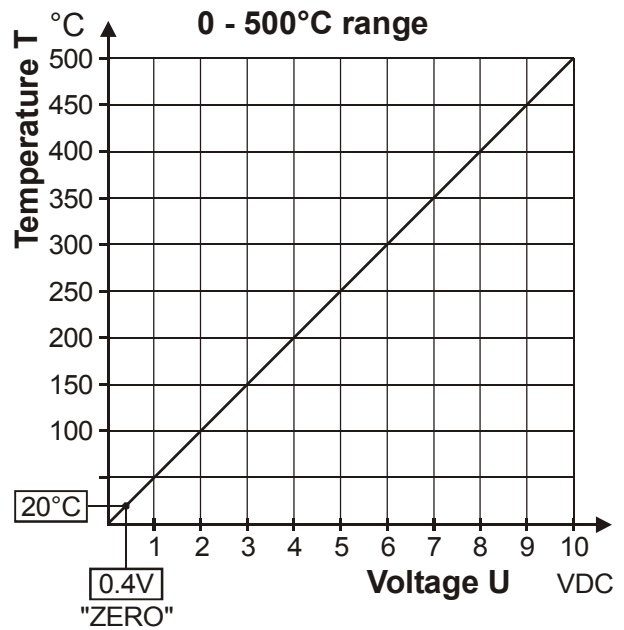
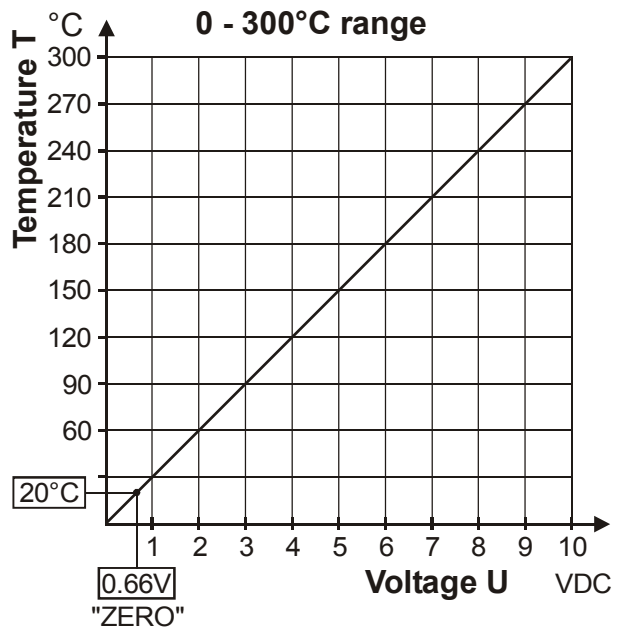

Only the two temperature ranges 300°C and 500°C appear at this actual value output. If a temperature range of 200°C is set for the controller with step 205 in the Configuration menu, it appears at this output in the 0...300°C range. A 400°C temperature range is indicated as 0...500°C.

An indicating instrument can be connected to this output in order to visualize the temperature of the heat-sealing band.

The characteristics of the ROPEX ATR-x temperature meter (size, scaling, dynamic response) are ideally

suited to this application (↪ section 4 "Accessories and modifications" on page 7).

It not only facilitates SET-ACTUAL comparisons, but also enables other criteria such as the heating rate, set point reached within the specified time, cooling of the heatsealing band etc. to be evaluated.

This meter moreover permits disturbances in the control loop (loose connections, contacting or wiring problems) as well as any line disturbances to be observed extremely effectively and interpreted accordingly. The same applies if mutual interference occurs between several neighboring control loops.

If a fault is signaled, this analog output is used – in addition to the value indicated on the controller – to display a selective error message (↪ section 9.27 "Fault areas and causes" on page 50).

If you want a fixed 10V reference voltage to appear at the analog output (terminal 24), you can configure this in the Configuration menu, step 216 (analog output):

- **Actual temperature (Factory setting)**
The actual value output indicates the current ACTUAL value as a 0...10VDC analog voltage.
- **10V reference**
A fixed 10VDC reference voltage is output at the actual value output.

9.8 Automatic zero calibration (AUTOCAL)

Owing to the automatic zero calibration (AUTOCAL) function, there is no need to adjust the zero point manually on the controller. The "AUTOCAL" function matches the controller to the current and voltage signals that are present in the system. This function can be activated in two ways:

- By means of a 24VDC signal at terminals 20+25.

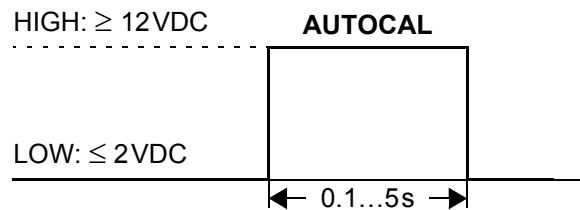
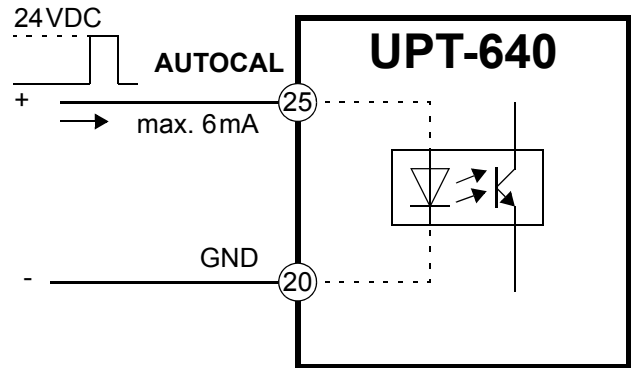

- By selecting step 107 in the Settings menu and pressing the "ENTER" key

The initial temperature (ambient temperature) of the heatsealing bar(s) which is currently valid for calibration can be set beforehand in the 0...40°C range using the "UP" and "DOWN" keys.

The zero point is calibrated in the factory to 20°C. The automatic calibration process takes around 10...15 seconds. The heatsealing band is not heated until the calibration process has finished.

The message "- Calibration - Please wait..." appears on the display while the "AUTOCAL" function is executing and a counter counts down from 13 to 0. The actual value output (terminals 20+24) is set to 0...3°C (corresponds to app. 0VDC) for the duration of the calibration process.

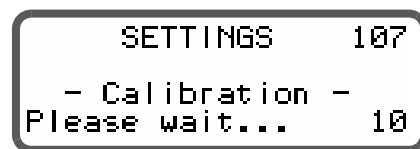

If the temperature of the heatsealing band varies on controllers as of software revision 100, the "AUTOCAL" function is executed a maximum of three times. If the function still cannot be terminated successfully, an error message appears (↪ section 9.27 "Fault areas and causes" on page 50).

! You should always wait for the heatsealing band and the bar to cool down (to ambient temperature) before activating the "AUTOCAL" function.

Reasons for disabled AUTOCAL function:

1. The "AUTOCAL" function cannot be activated if the heatsealing band cools down at a rate of more than 0.1K/second. This is additionally indicated with step 107 in the Settings menu by the message "Heatsealing band still hot! Please wait...". This message is also displayed if the controller cannot be calibrated when the external "AUTOCAL" signal is activated (cooling rate too fast).
2. If the "START" signal (24VDC or contact) or the "CH1" signal (24VDC or contact) is activated, the AUTOCAL function is not executed. This is additionally indicated with step 107 in the Settings menu by the message „Autocal locked ! (START-Sig. active)“ or „Autocal locked ! (CH1-Sig. active)“.
3. Directly after the controller is powered up, the AUTOCAL function cannot be activated if a fault with error code 101...103, 201...203, 801 or 9xx occurs (↪ section 9.27 "Fault areas and causes" on page 50). If the controller has already operated correctly - a minimum of once - after powering up, the AUTOCAL function cannot be activated with error codes 201...203, 801 or 9xx.

! The base resistance of the heating elements rises continuously during operation (construction-conditioned). Due to this the AUTOCAL function must be executed every 100.000 sealing cycles for preventing measurement failures of the ACTUAL temperature.

9.9 "START" signal (HEAT)

The heating process is activated by means of the "START" signal in different ways, depending on the time control status (timer function) (↪ Configuration menu, step 209) :

1. Time control off (deactivated):

When the "START" signal is activated, the controller-internal set/actual comparison is enabled immediately and the heatsealing band is heated up to the SET temperature. It remains at this temperature until the signal is deactivated again. This process can also be started independently of the "START" signal by pressing the "HAND" key while

the display is in the home position.

2. Time control on (activated):

If time control (timer function) is on, activating the "START" signal starts the internally parameterized timeout. The time at which the heatsealing band begins to heat up depends on the setting of this parameter. The "START" signal must be deactivated again before the next timeout is activated.

Pressing the "HAND" key while the display is in the home position causes the heatsealing band to start heating up immediately (as described in 1). The internal timeout is not started.

The "START" signal can be activated in two ways:

- By means of a 24VDC signal at terminals 3+4.

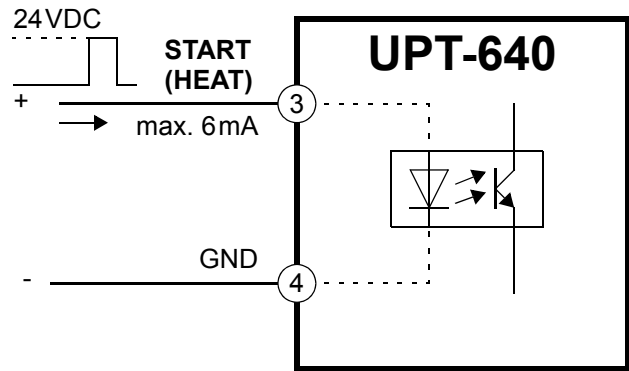

HIGH: $\geq 12\text{VDC}$

LOW: $\leq 2\text{VDC}$

START (HEAT)
or
START TIMER

- By means of a control contact at terminals 2+7

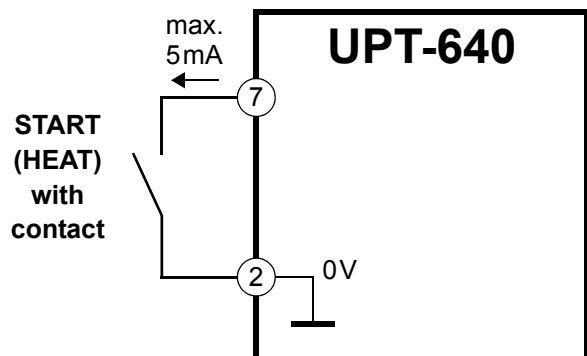

! The "START" signal is disabled as long as the AUTOCAL function is executing in the Settings menu (with step 107) or the "RESET" signal is active.

The set point that is selected for the heatsealing temperature (step 101 in the Settings menu) must be greater than 40°C. If not, the heatsealing band will not be heated up.

The alarm relay is switched if the "START" signal is activated while an error message is indicating error codes 104...105, 111...113 or 211 (↪ section 9.27 "Fault areas and causes" on page 50). The heatsealing band is likewise not heated.

9.10 "RESET" signal

The CIRUS temperature controller UPT-640 (as of SW 100) can be reset by means of an external "RESET" signal at terminals 20+26.

As a result:

- A heatsealing cycle is aborted if one is in progress
- No more measuring impulses are generated
- An error message is reset if one is present

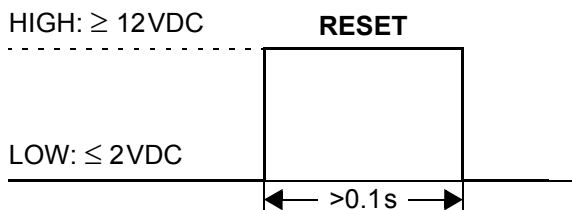
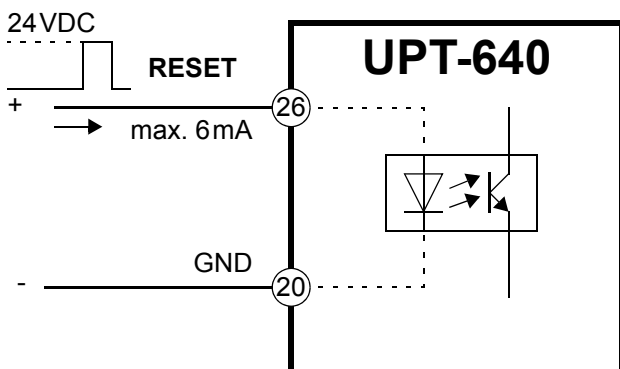

The actual value output changes to 0...3°C (i.e. approximately 0VDC) while the "RESET" signal is being activated. This may be interpreted by the higher-level controller (e.g. a PLC) as feedback.

The message "External RESET signal active" is additionally displayed on the controller when the "RESET" signal is active.

The "AUTO CAL" function is not aborted if the "RESET" signal is activated while it is still executing.

! The controller executes an internal initialization for approximately 500ms after the "RESET" signal is deactivated. The next heatsealing process cannot be started until it has finished.

! If a contactor Kb is used to deactivate the control loop (↪ Kap. 7.3 „Power supply“ auf Seite 13), it must be energized again 50ms at the latest after the "RESET" signal is deactivated. If it is energized too late, an error message will be output by the controller.

9.11 Correction factor Co

The correction factor Co permits the UPT-640 controller to be adapted to the real conditions in the machine (type of UPT heating element, impulse transformer specification, length of connecting wires, cooling etc.).

Proceed as follows to determine the optimum correction factor Co (setting in step 6):

1. Controller settings:
 - Set temperature: 160...180°C (step 101)
 - Hold function: 2s (step 105)
2. Activation of sealing pulses with of 0.2...0.3s.

Slowly increase the correction factor – starting either with the lowest value (50%) or with the value recommended in the ROPEX Application Report minus 25% – to the indicated hold value = set temperature.

The correction factor should be checked, and if necessary corrected, whenever the machine is operated or the set temperature or the heatsealing time are changed.

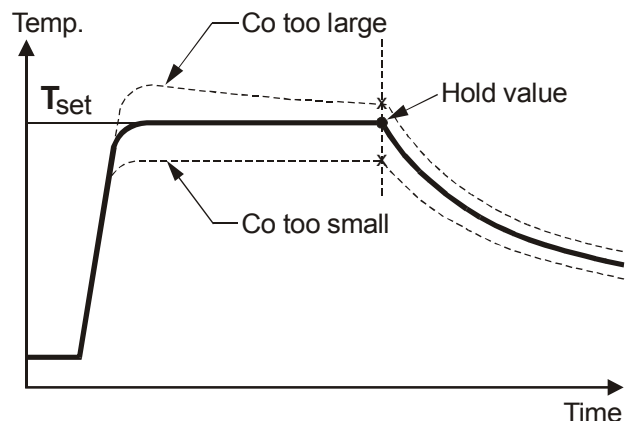

9.12 Maximum starting temperature

You can set the required maximum starting temperature in step 224. This temperature is the maximum permissible actual value at the start time. The value is determined by the controller at the start of each impulse and compared with the value set in step 224.

This function serves to monitor the cooling circuit.

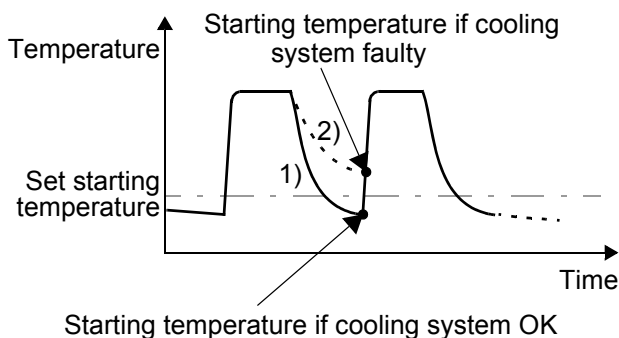

If the cooling system is intact, the tool is cooled down according to curve 1). If the cooling system is faulty, it is cooled down according to curve 2) because the water is no longer cooled. As a result, the temperature is always at least the value set with this menu step. In this case, the controller ignores the next heating command and reports an alarm. The corresponding error code 305 is indicated and the fault output is switched (↪ section 9.27 "Fault areas and causes" on page 50). This prevents the UPT sealing bar from being damaged beyond repair.

! The maximum value of the setting range is limited either by the maximum value specified with step 206 in the Configuration menu or by the temperature range set with step 205.

Setting:

We advise you not to set this parameter until you have determined the optimum heatsealing parameters (temperature and cooling time) for productive operation. The starting temperature should be set to approximately 50% of the heatsealing temperature for the trial

run, to enable the optimum working parameters to be established correctly.

9.13 Cycle counter

Each activation of the "START" signal during operation is detected by a cycle counter integrated in the controller. Actuations of the "HAND" key are not counted. The counter reading can be displayed with step 214 in the Configuration menu.

The cycle counter is reset to 0 if the "ENTER" key is pressed or if the maximum count of 999.999.999 cycles is exceeded.

9.14 Hold mode

The behavior of the digital indication of the ACTUAL temperature in the home position can be changed with step 106 in the Settings menu. The following settings are possible:

1. **"OFF" (Factory setting)**
If the main menu is visible on the display, the real ACTUAL temperature is always indicated.
2. **"ON"**
If the display is in the home position, the ACTUAL temperature that was valid at the end of the last heatsealing phase is always indicated as a digital value. When the controller is switched on, the real ACTUAL temperature is indicated until the end of the first heating phase.
3. **"2 s"**
It causes the current ACTUAL temperature to be displayed as a digital value for an additional 2 seconds at the end of a heatsealing phase. This temperature is then indicated again in real time until the end of the next heating phase.

! Hold mode only affects the digital value on the display. The ACTUAL temperature in real time is always indicated, regardless of the setting, by the dynamic bar and the actual value output.

The various hold modes are shown below:

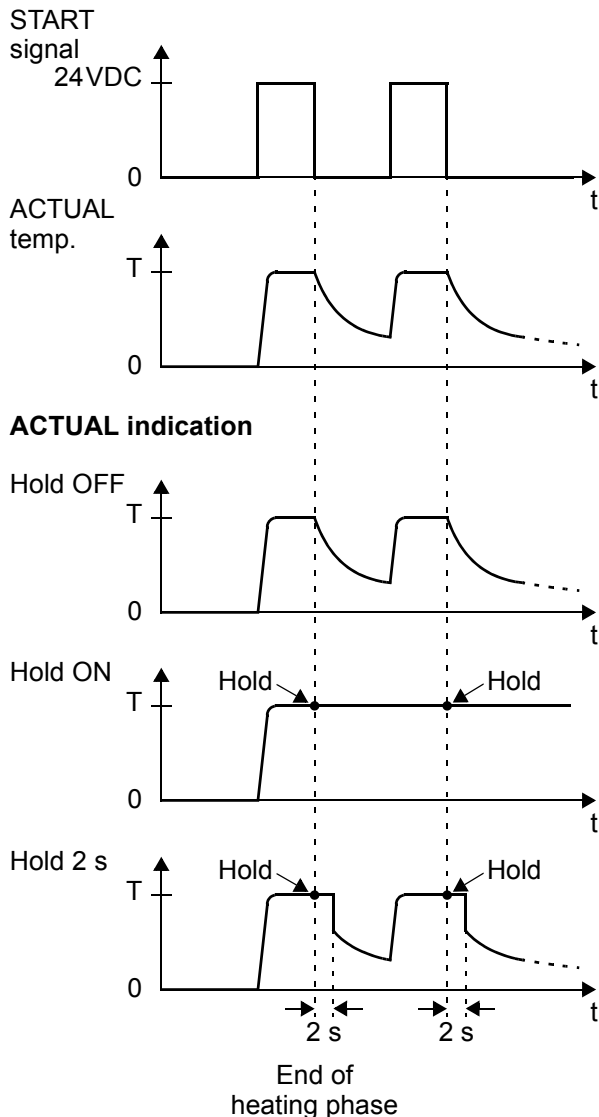

The word "Hold" appears on the display if a temperature value is indicated in hold mode. It disappears for approximately 100ms whenever the hold value is updated.

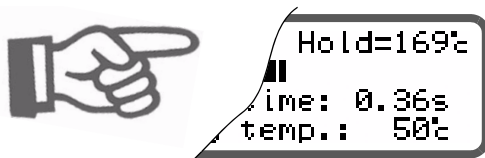

9.15 Measuring impulse duration

The length of the measuring impulses generated by the controller can be set with this parameter by means of

step 220. It may be necessary to set a measuring impulse that is longer than the default 1.7 ms for certain applications (↪ ROPEX Application Report).

9.16 Locking the "HAND" key

The "HAND" key function can be configured with step 213 in the Configuration menu when the display is in home position.

This prevents the heatsealing bands from being heated if the "HAND" key is pressed inadvertently.

The following settings are possible:

1. Lock „OFF“ (**Factory setting**)
Pressing the "HAND" key while the display is in the home position starts a manual heating process. The heatsealing band is heated as long as the "HAND" key remains pressed.
2. Lock „ON“
The "HAND" key is locked when the display is in the home position, in other words it has no function.

9.17 Temperature unit Celsius / Fahrenheit (as of software revision 103)

As of software revision 103 the unit for the temperature indication and value selection can be switched between °C (Celsius) and °F (Fahrenheit).

1. „Celsius“ (**Factory setting**)
Temperature indication and value selection in Celsius (°C).
2. „Fahrenheit“
Temperature indication and value selection in Fahrenheit (°F)

Up to software revision 102 only Celsius (°C) can be specified on the controller as the temperature unit.

! The degree unit can be changed on the controller without interrupting operation

! If you specify temperature indication and value selection in Fahrenheit (°F), the controller still uses Celsius (°C) internally. Value steps are therefore possible with this function owing to the conversion from Celsius to Fahrenheit.

9.18 Disabling the Configuration menu

It is possible to disable all changes to values/parameters in the Configuration menu. This prevents the controller configuration from being tampered with by unauthorized persons.

The Configuration menu can be disabled or enabled by pressing the "MENU" key for 2.0seconds while the power-up message is displayed (after switching on the controller, see section 9.2.1 "Power-up message" on page 23). The display then shows a message confirming that the disable function is active for 3.0seconds before returning to the home position.



The same message is also displayed for 5.0seconds when you open the Configuration menu to indicate that this menu is disabled.

! You can still display all steps, values and parameters even if the Configuration menu is disabled. You are no longer allowed to enter or change values, however.

The Configuration menu remains disabled until the disable function is canceled again. To do so, repeat the above procedure (press the "MENU" key for 2.0seconds while the power-up message is displayed). The display then shows a message confirming that the disable function has been canceled.

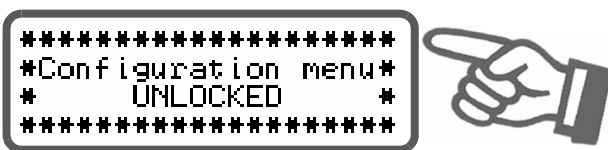

In the factory setting the Configuration menu is not disabled.

9.19 Setting the display brightness (VF display only)

If the display is in the home position, the brightness of

the VF display (blue) can be set in 4 steps (25%, 50%, 75%, 100%) with the "UP" and "DOWN" keys. The factory setting is 75%.

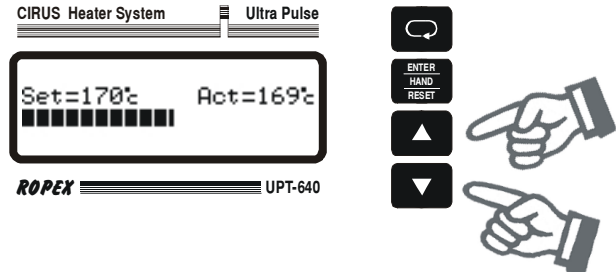

The life of the VF display can be prolonged by reducing the brightness.

9.20 Undervoltage detection

Trouble-free operation of the temperature controller is guaranteed within the line voltage tolerance range specified in section 5 "Technical data" on page 9.

If a line voltage which is less than the lower limit of the permissible range occurs, the controller is switched to a standby mode. No more heatsealing processes take place and no more measuring impulses are generated. The display changes to indicate this.

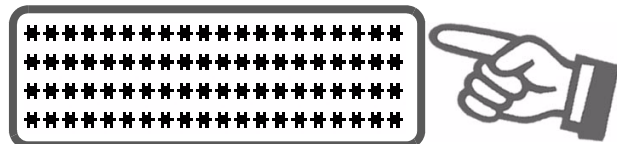

The main menu is displayed again, and operation is resumed, when the input voltage returns to the specified tolerance range.

The alarm relay is not switched if an undervoltage condition occurs. The standby mode is indicated by 0...3°C (corresponds to app. 0V) at the analog output.

! Trouble-free operation of the controller is only guaranteed within the specified input voltage tolerance range. An external voltage monitor must be connected to prevent defective heatseals as a result of low line voltage.

9.21 Diagnostic interface/visualization software

An interface with a 6-pole Western socket is provided for systemdiagnostics and process visualization. This interface allows a data connection to be set up to the ROPEX visualization software using the ROPEX communication interface CI-USB-1.

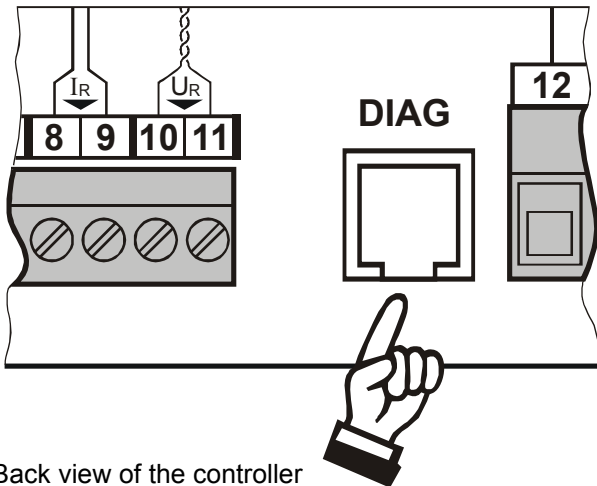

Back view of the controller

! Only a ROPEX communication interface is allowed to be connected to the diagnostic interface. Connecting another device (e.g. a telephone cable) could result in malfunctions or damage to the controller.

The ROPEX visualization software is described in a separate document.

9.22 Booster connection

The UPT-640 (as of SW 100) controller has a connection for an external switching amplifier (booster) as standard. This connection (at terminals 1+2) is necessary for high primary currents (continuous current > 5A, pulsed current > 25A). The switching amplifier should be connected as described in section 7.7 "Wiring diagram with booster connection" on page 16. No settings are required in the menu.

9.23 Time control (timer function)

9.23.1 Activation and indication

! The settings described here are only allowed to be entered by technically trained persons. An incorrectly parameterized timer function may cause disruptions to operation and damage to the machine.

The timer function is activated with step 209 [26] in the Configuration menu. There are two possible settings in this menu:

1. **"OFF" (Factory setting)**
Time control (timer function) deactivated
2. **"ON"**
Time control (timer function) activated.
The internal timeout is started by activating the "START" signal. The timeout either ends with the parameterized cooling phase or is interrupted by activating the "RESET" signal.
3. **"ON with START monitoring"**
Time control (timer function) activated and "START" signal monitored.
Once again, the internal timeout is started by activating the "START" signal. In this setting, however, the "START" signal must remain activated until the end of the parameterized cooling phase. If the "START" signal is deactivated before the end of the cooling phase - or if the "RESET" signal is activated - the timeout is interrupted.

If time control is on, activating the "START" signal starts the internally parameterized timeout. This timeout comprises:

- Starting delay (delay at the beginning of the heating phase)
- Heating phase (heating and control process)
- Cooling phase
- Relay K1 function

! If time control (timer function) is activated, it is only possible to start a heating process with the "HAND" key on the controller. The timeout

of the internal time control cannot be started with this key.

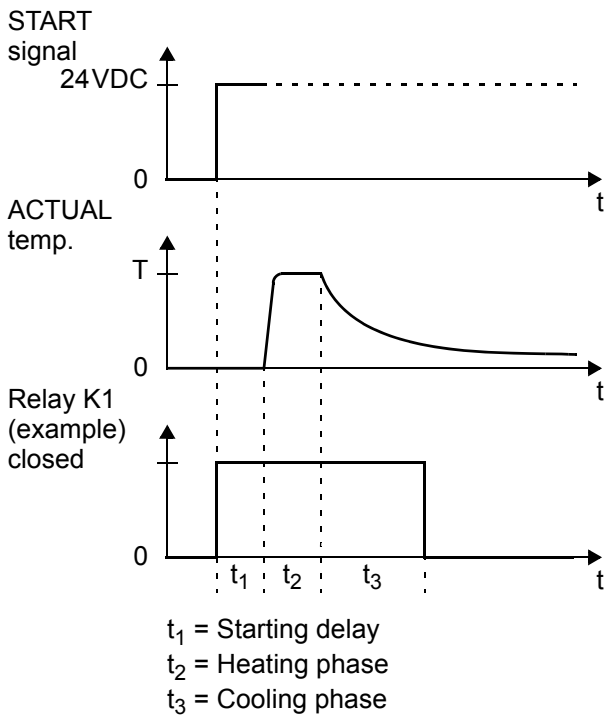

! The timeout of the internal time control (timer function) can be interrupted by switching off the controller. It can also be interrupted by deactivating the "START" signal if time control "ON with START monitoring" is configured.

If the display is in the home position, the individual timeouts can be monitored there. The remaining heatsealing time is indicated on the display in the form of a countdown at the end of the heating phase. A direction arrow indicates the active process.

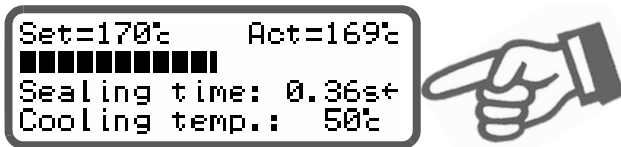

The active cooling phase is subsequently marked with the direction arrow at the end of the heating phase.

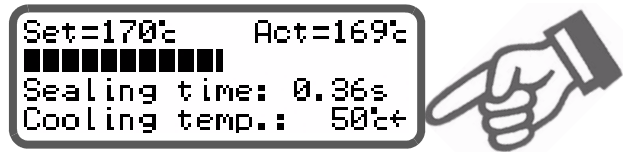

The direction arrow disappears again at the end of the cooling phase (i.e. at the end of the internal timeout). The current condition of relay K1 is indicated by means of a separate icon. If the icon is visible, the normally open contact of the relay is closed.



Separate settings can be entered for the individual timeouts. These settings are possible with steps 103, 104 and 105 in the Settings menu and with steps 210 and 212 in the Configuration menu. The options available with these advanced settings are described below.

9.23.2 Setting the starting delay

The start of the heating process can be explicitly delayed by entering a starting delay time with step 103 in the Settings menu, e.g. in order to bridge the closing time of the heatsealing bars. When the "START" signal is activated, the controller waits for the time specified with this menu step to elapse before commencing the heating process.

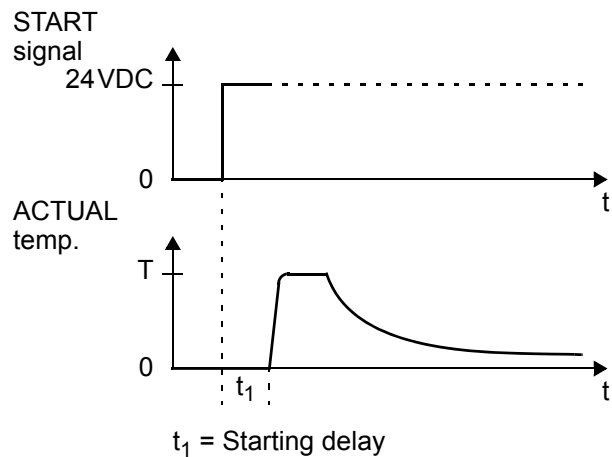

The starting delay can be set in the range from 0 to 9.99s. A delay of 0s is defined as the factory setting. In this case, the heating process begins as soon as the "START" signal is activated.

9.23.3 Setting the heatsealing time

This menu step is used to enter the heatsealing time. There are two possible ways to set the heatsealing time:

1. **"0...5.00s"**

The heatsealing time can be set in the range from 0 to 99.9s. The factory setting is 0.1s.

2. **"EXT"**

(This setting is possible as of software revision 013)
The heatsealing time is controlled by the "START" signal (24VDC signal applied to terminals 3+4 or contact applied to terminals 2+7). The duration of the heatsealing time is equal to the active time of the "START" signal.

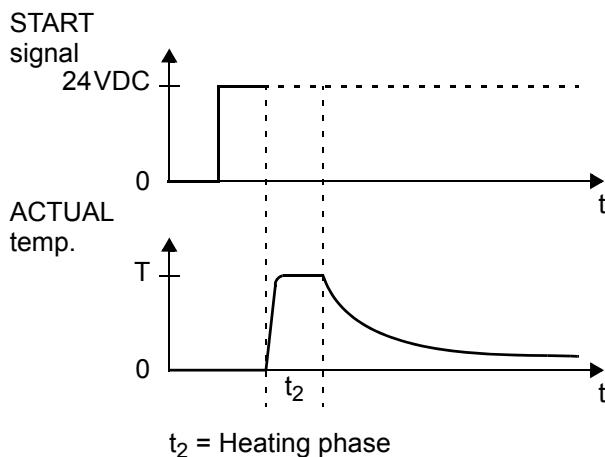

9.23.4 Setting the cooling mode

Various criteria for the end of the cooling phase can be specified with step 210 in the Configuration menu of the UPT-640 (as of SW 100) controller. The possible settings are as follows:

1. **"Absolute" (Factory setting)**

The cooling phase ends when the ACTUAL temperature of the heatsealing band falls below a specified temperature value. This cooling temperature can be set with step 105 in the Settings menu.

2. **"Relative"**

The cooling phase ends when the ACTUAL temperature falls to a value corresponding to X% of the SET temperature. This percentage cooling value can be set with step 105 in the Settings menu.

Example:

SET temperature = 180°C, cooling value = 60%
→ Cooling phase ends when ACTUAL temperature $\leq 108^\circ\text{C}$

3. **"Time"**

The cooling phase ends after a specified time in seconds and is independent of the ACTUAL temperature. This cooling time can be set with step 105 in the Settings menu.

The various cooling modes are shown below:

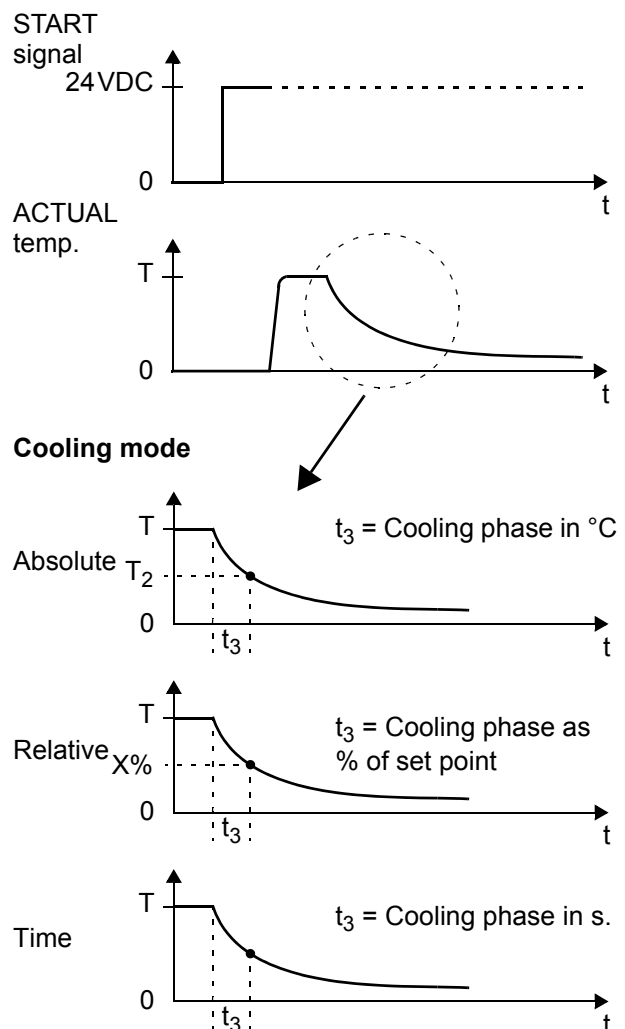

9.23.5 Setting the cooling value

After the cooling phase has been configured with step 210 in the Configuration menu (↪ section 9.23.4 "Setting the cooling mode" on page 40), you can specify the cooling parameters with step 105 in the Settings menu.

 **The options available with step 105 in the Settings menu vary according to the selection made with step 210 in the Configuration menu. All settings entered with menu step 105 are overwritten if step 210] is changed subsequently.**

The possible settings are as follows:

1. **"Cooling temp. in °C"**

(if setting with menu step 210 = "Absolute")

The cooling phase of the internal timeout ends when the ACTUAL temperature of the heatsealing band falls below the set temperature.

The minimum settable temperature is 50°C. This is also the factory setting.

 **The maximum value of the setting range is limited either by the maximum value specified with step 206 in the Configuration menu or by the heatsealing band type/temperature range set with step 205.**

2. **"Cooling temp. in %"**

(if setting with menu step 210 = "Relative")

The cooling phase of the internal timeout ends when the ACTUAL temperature falls to the specified percentage of the SET temperature. This value can be set between 40 and 100%.

The factory setting is 40%.

3. **"Cooling time in s"**

(if setting with menu step 210 = "Time")

The cooling phase ends when the specified time

elapses. This time can be set between 0 and 9.99s. The factory setting is 1.00s.

9.23.6 Relay K1 (with time control)

The function of relay K1 when time control is active is also specified with step 212 in the Configuration menu (↪ section 8.3.7 "Relay K1 (without time control)" on page 19). The settings described here are only possible if time control is active. These settings can be selected as follows:

1. **„OFF“**

Relay K1 without function

2. **"When start signal present"**

The normally open contact of relay K1 closes as soon as the "START" signal is activated and remains closed until the end of the parameterized timeout (i.e. until the end of the cooling phase).

3. **"When temperature reached"**

(Factory setting)

The normally open contact of relay K1 closes when the ACTUAL temperature reaches 95% of the SET temperature and remains closed until the end of the parameterized timeout (i.e. until the end of the cooling phase).

4. **"While cooling"**

The normally open contact of relay K1 closes at the end of the heating phase and opens again at the end of the cooling phase.

This configuration permits air cooling to be activated with relay K1 during the cooling phase, for instance.

5. **"End-of-cycle impulse"**

The normally open contact of relay K1 closes at the end of the parameterized timeout (i.e. at the end of the cooling phase) and opens again after approximately 500 ms. If a "START" signal is activated while relay K1 is still closed, the relay opens again immediately.

The possible settings are shown below:

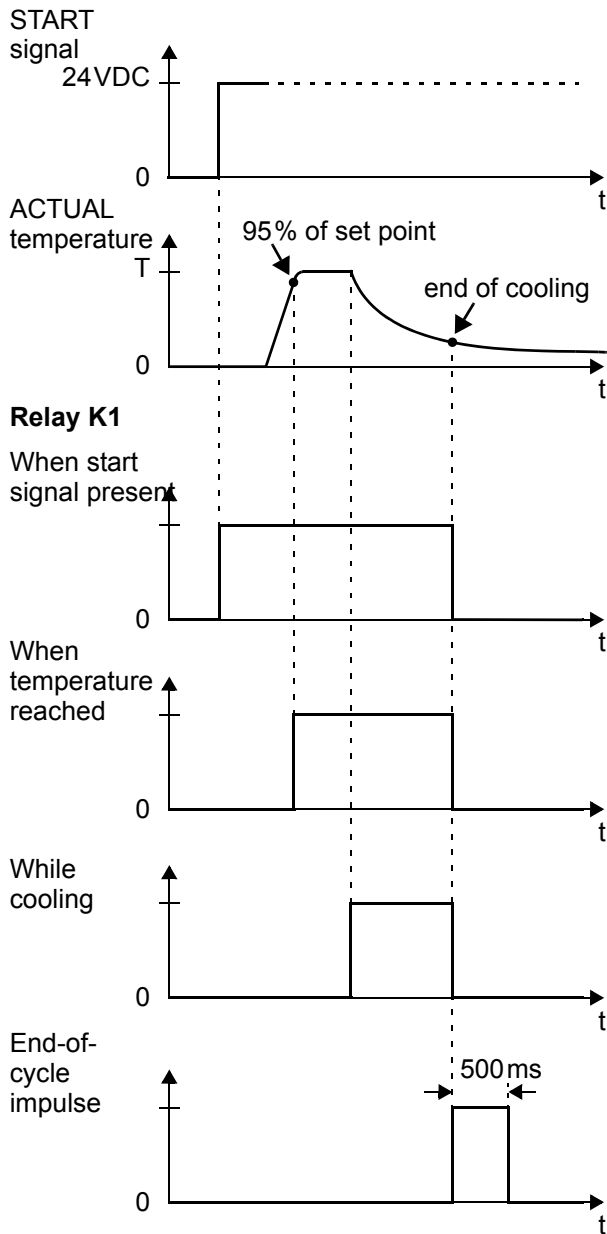

6. "Active if Tact = Tset"

Relay K1 is activated if the actual value is inside the specified temperature tolerance band (steps 207, 208). If the actual temperature is outside the toler-

ance band, relay K1 is deactivated (see graph below).

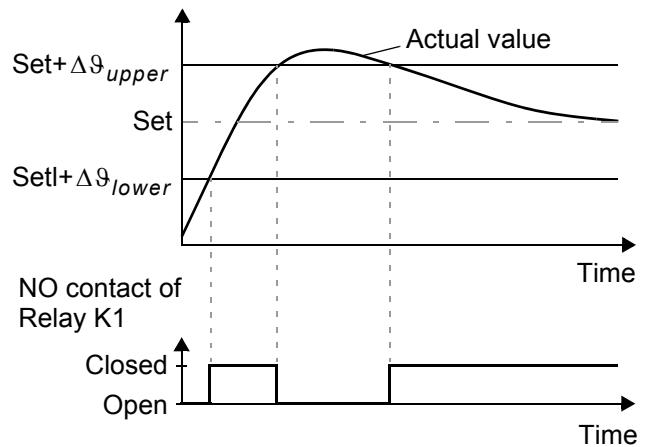

7. "Active if Tact = Tset", with latch function

Relay K1 is closed if the actual value is inside the specified temperature tolerance band (steps 207, 208). If the actual temperature leaves the tolerance band once during the heatsealing phase, relay K1 is opened. The relay is not closed again until the next "START" signal is activated. The switching state of relay K1 can thus also be interrogated by the higher-level PLC after a heatsealing process (latch function, see graph below).

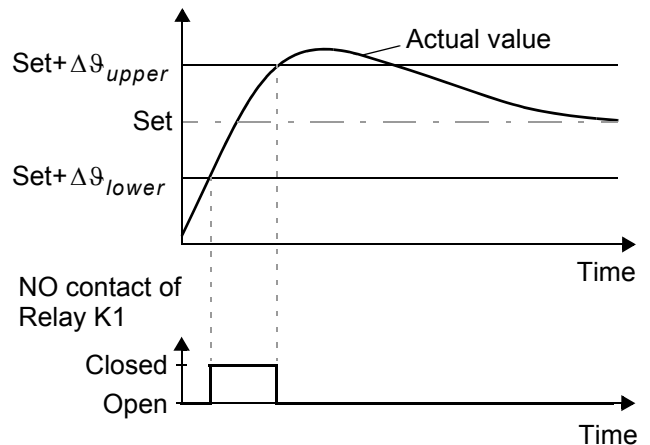

9.23.7 "Output 1"/ „Temperature OK“ signal (with time control)

! On controllers up to software revision 022, the switching output at terminals 20+21 was called "Temperature OK". The more general name "Output 1" is used as of software revision 100 because this output now also supports other functions.

The "Output 1" signal is available at terminals 20+21 as a digital control signal.

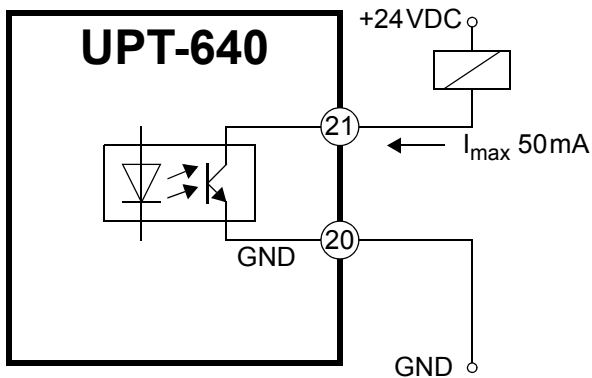

If time control (timer function) is active, the switching output at terminals 20+21 ("Output 1") can be parameterized in the same way as relay K1. The options for "Output 1" are specified with step 222 in the Configuration menu as followed:

1. "Off"
2. "When start signal present"
3. "When temperature reached"
4. "While cooling"
5. "End-of-cycle impulse"
6. "Active if Tact = Tset"
7. "Active if Tact = Tset", with latch function (factory setting)

For a detailed description of these functions, see section 9.23.6 "Relay K1 (with time control)" on page 41.

9.24 Release impulse

If a film sticks to the heating element after the heatsealing process, it can be released by subsequently applying

lyng a short heat impulse and simultaneously tautening it.

The principle is shown in the diagram below.

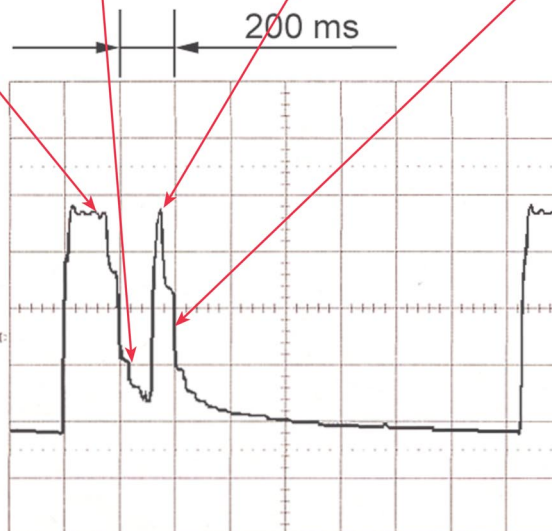
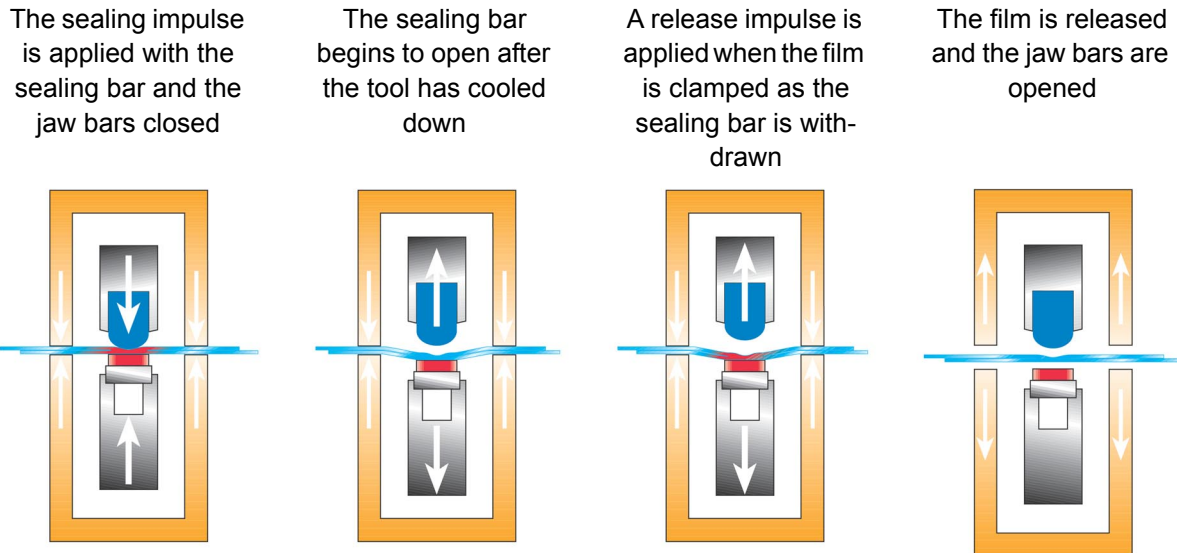

The release impulse can be generated in various ways, to enable it to be applied at exactly the right instant in the heatsealing sequence. The temperature and duration of this impulse can be set individually.

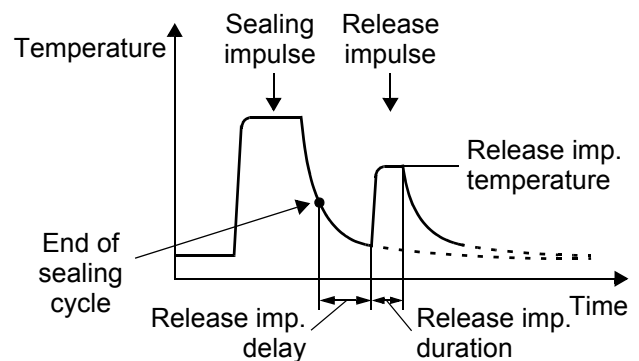

9.24.1 Temperature setting

The temperature of the release impulse can either be set in step 115 or specified by applying an external voltage at the analog input (terminals 23+20).

! The release impulse temperature is set in the same way as described for the temperature selection function (set point selection). Please heed the instructions and recommendations contained in section 9.6 "Temperature setting (set point selection)" on page 30!

9.24.2 Impulse generated internally

The timer function must be set to "ON with internal release imp." for this purpose in step 209 (↪ section 9.23 "Time control (timer function)" on page 38).

The timeout for the release impulse then begins immediately after the end of the heatsealing phase (i.e. at the end of the cooling phase). You can also configure a delay (step 11) and a duration (step 12) for the release impulse in addition to the temperature.

! A release impulse is not generated if the release temperature (step 115) or the impulse duration (step 117) are set to "0".

9.24.3 Impulse generated externally

If this configuration is selected, the release impulse is controlled by activating the external control signal CH1. This signal can be activated in two ways:

- By means of a 24VDC signal at terminals 22+4.

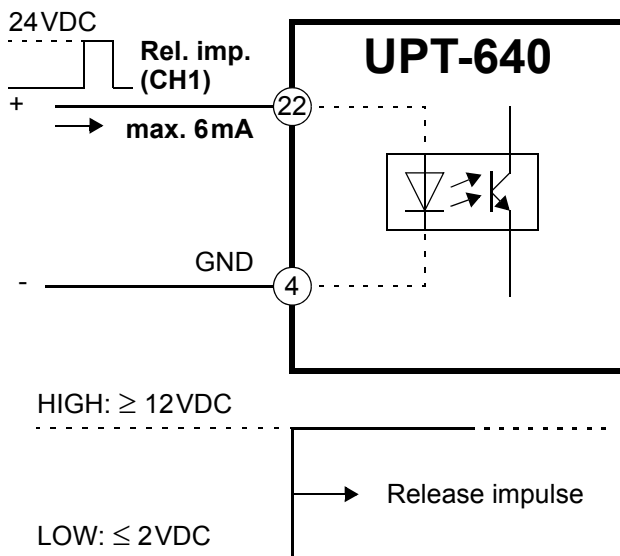

- By means of a control contact at terminals 2+19.

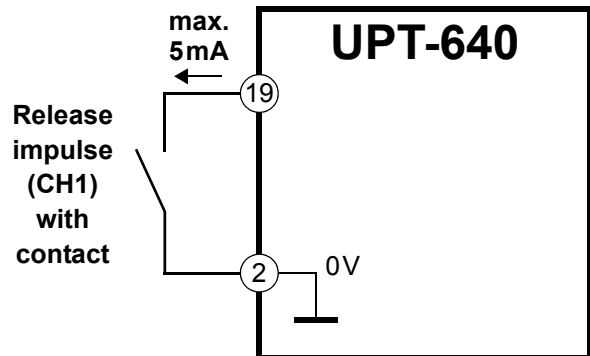

The following functions are possible, depending on the time control setting in step 37 (↪ section 9.23 "Time control (timer function)" on page 38):

1. If time control is "OFF"

The delay and the impulse duration cannot be specified internally by the controller. The start and duration of the release impulse are dependent on the activation of the external control signal CH1 (terminals 22+4 and 2+19).

! The maximum impulse duration is limited internally by the controller to 5seconds, in order to avoid damaging the heating element. If this time limit is exceeded, heating is terminated automatically.

2. If time control is "ON with external release imp."

With this setting the delay (step 116) and the duration (step 117) of the release impulse are specified by the controller.

The release impulse (i.e. the delay) starts when the external control signal CH1 is activated.

! A release impulse cannot be started until the end of the heatsealing cycle (i.e. the end of the cooling phase). If the CH1 control signal is activated earlier – or if the temperature and the impulse duration (steps 115 and 117) are set to "0" – a release impulse is not generated.

9.25 System monitoring/alarm output

To increase operating safety and to avoid faulty heatsealing, the controller incorporates special hardware and software features that facilitate selective fault detection and diagnosis. Both the external wiring and the internal system are monitored.

These features crucially support the system owner in localizing the cause of an abnormal operating state. A system fault is reported or differentiated by means of the following elements.

A.) Error message on the display:

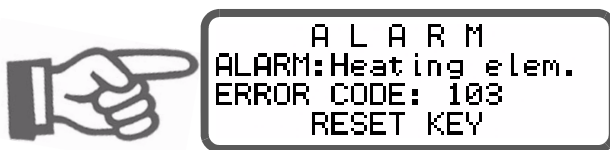

The cause of a fault can be localized quickly and easily with the help of the error code that appears on the display. Please refer to section 9.27 "Fault areas and causes" on page 50 for a list of the possible error codes.

B.) Alarm relay (relay contact, terminals 5+6):

This contact is set in the factory as follows:

- **OPEN** if error code 104...106, 111...113 or 211 is displayed. The contact closes, however, if a "START" signal is activated in this state.
- **CLOSED** if error code 101...103, 107, 108, 201...203, 801 or 9xx appears.

If the alarm relay is configured differently from the factory setting (↪ section 8.3.11 "Configuration of the alarm relay" on page 20), these states are inverted.

C.) Error code output via the 0 to 10VDC actual value output (terminals 20+24):

Since a temperature indication is no longer necessary if a fault occurs, the actual value output is used to display error codes in the event of a fault.

13 voltage levels are offered for this purpose in the 0...10VDC range, each of which is assigned an error code (↪ section 9.27 "Fault areas and causes" on page 50).

If a state that requires AUTOCAL occurs – or if the controller configuration is incorrect – (error codes 104...106, 111...113 or 211), the actual value output jumps back and forth at 1 Hz between the voltage value

that corresponds to this error and the end of the scale (10VDC, i.e. 300°C or 500°C). If the "START" signal is activated in one of these states, the voltage value does not change any more.

Selective fault detection and indication can thus be implemented simply and inexpensively using the analog input of a PLC with a corresponding error message (↪ section 9.27 "Fault areas and causes" on page 50).

! An error message can be reset by pressing the "RESET" key, by activating the "RESET" signal at terminals 20+26 (↪ section 9.10 ""RESET" signal" on page 34) or by switching the controller off and then on again.

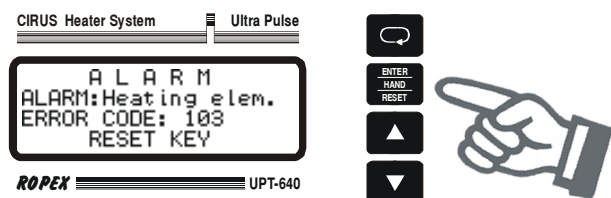

! Invalid error messages may appear when the controller is switched off owing to the undefined operating state. This must be taken into account when they are evaluated by the higher-level controller (e.g. a PLC) in order to avoid false alarms.

9.26 Error messages

The table below shows how the analog voltage values that appear at the actual value output correspond to the faults that have occurred. It also describes each fault and the required corrective action. The block diagram in section 9.27 "Fault areas and causes" on page 50 permits each fault to be cleared quickly and efficiently. The error codes described below can also be displayed in the ROPEX visualization software (↪ section 9.21 "Diagnostic interface/visualization software" on page 38) to facilitate troubleshooting.

! If the actual value output is evaluated in order to identify an error message - in the higher-level controller, for instance - the tolerance window must be adjusted to prevent it from being incorrectly interpreted. Please note the tolerances of the actual value output (↪ section 5 "Technical data" on page 9).

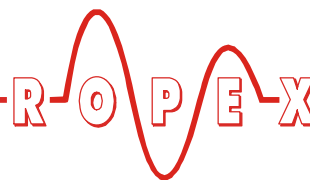

Part 1 of 3:							
Error code	Act. value output; Voltage [V]	Temp. 300 °C [°C]	Temp. 500 °C [°C]	STATUS of alarm relay (factory set.)	Cause	Action if machine started for first time	Action if machine already operating, HS element not chang.
1	0,66	20	33	Closed	I _R signal missing	Fault area ①	Fault area ①
2	1,33	40	66		U _R signal missing	Fault area ③	Fault area ③
3	2,00	60	100		U _R and I _R signals missing	Fault area ②	Fault area ②⑨
107 108					Temperature step, down Temperature step, up	Fault area ④⑤⑥ (loose contact)	Fault area ④⑤⑥ (loose contact)
4	2,66	80	133		Temperature too low/high (↘ section 8.3.9)		
5	3,33	100	166		Frequency fluctuation, inadmissible line frequency	Check power supply	Check power supply
6	4,00	120	200		Heatup time too long (↘ section 8.3.10) Starting temperature too high (↘ section 9.12)	Run RESET	Run RESET
7	4,66	140	233		Int. fault, contr. defective Triac defective Int. fault, contr. defective Int. fault, contr. defective Int. fault, contr. defective	Replace controller Replace controller Replace controller Replace controller Replace controller	Replace controller Replace controller Replace controller Replace controller Replace controller
917 918					Plug-in jumper for alarm relay wrong	Check plug-in jumper	Check plug-in jumper

Part 2 of 3:							
NOTE: The specified error messages are initially output as warnings (actual value output jumps back and forth between two values; alarm relay is open). When the "START" signal is activated, the warning changes to a fault (actual value output no longer jumps back and forth, see bold italic values ; alarm relay is closed).							
Error code	Act. value output; Voltage [V]	Temp. 300°C [°C]	Temp. 500°C [°C]	STATUS of alarm relay (factory set.)	Cause	Action if machine started for first time	Action if machine already operating, HS element not chang.
8	104			Warning: Open Fault: Closed (voltage value at actual value output then no longer changes)	I _R signals incorrect, incorrect specification of impulse-transformer	Run AUTOCAL , Check specification of transformer, Fault area ⑦⑧	Fault area ④⑤⑥ (loose contact)
					105		
	106	↕ 5,33 ↕ ↕ 10 ↕	↕ 160 ↕ ↕ 300 ↕		UR and/or I _R signals incorrect, incorrect specification of impulse-transformer		
		302			Temperature too low, AUTOCAL wasn't performed, loose contact, ambient temp. fluctuates		
	303				temperature too high, AUTOCAL wasn't performed, loose contact, ambient temp. fluctuates		
9	211	↕ 6,00 ↕ ↕ 10 ↕	↕ 300 ↕ ↕ 500 ↕	Data error	Run AUTOCAL	---	

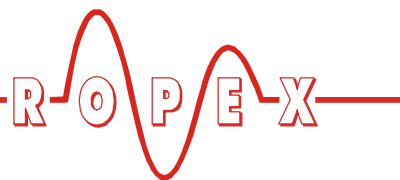

Part 3 of 3:												
<p>NOTE: The specified error messages are initially output as warnings (actual value output jumps back and forth between two values; alarm relay is open). When the "START" signal is activated, the warning changes to a fault (actual value output no longer jumps back and forth, see bold italic values; alarm relay is closed).</p>												
Error code	Act. value output; Voltage [V]	Temp. 300 °C [°C]	Temp. 500 °C [°C]	STATUS of alarm relay (factory set.)	Cause	Action if machine started for first time	Action if machine already operating, HS element not chang.					
10	↕ 6,66 ↕ ↕ 10 ↕	↕ 200 ↕ ↕ 300 ↕	↕ 333 ↕ ↕ 500 ↕	Warning: Open	I _R signal incorrect, calibration not possible	Fault area ⑧, check configuration	---					
11	↕ 7,33 ↕ ↕ 10 ↕	↕ 220 ↕ ↕ 300 ↕	↕ 366 ↕ ↕ 500 ↕					U _R signal incorrect, calibration not possible	Fault area ⑦, check configuration	---		
12	↕ 8,00 ↕ ↕ 10 ↕	↕ 240 ↕ ↕ 300 ↕	↕ 400 ↕ ↕ 500 ↕					Fault: Closed	U _R and I _R signals incorrect, calibration not possible	Fault area ⑦⑧, check configuration	---	
13	↕ 8,66 ↕ ↕ 10 ↕	↕ 260 ↕ ↕ 300 ↕	↕ 433 ↕ ↕ 500 ↕	(voltage value at actual value output then no longer changes)	Temperature fluctuates, calibration not possible							
114					Ext. calibration temperature too high,							
115					Ext. calibration temperature fluctuates							
116												

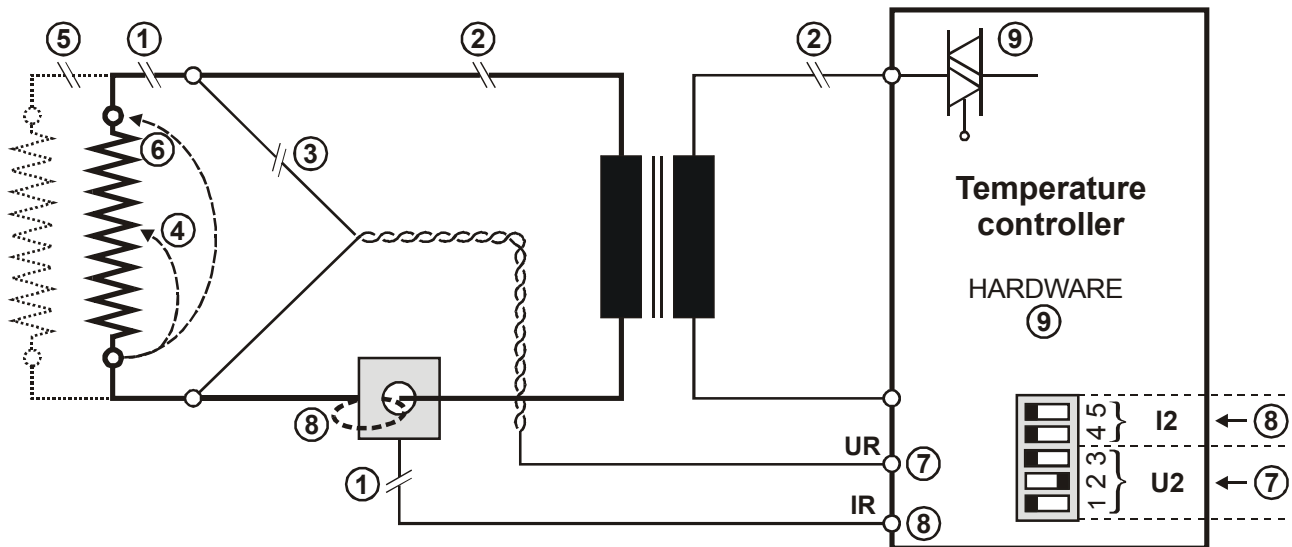
9.27 Fault areas and causes

The table below explains the possible fault causes.

Fault area	Explanation	Possible causes
①	Load circuit interrupted after U_R pickoff point	- Wire break, heatsealing band break - Contacting to heatsealing band defective
	PEX-W2/W3 current transformer signal interrupted	- I_R measuring wire from current transformer interrupted
②	Primary circuit interrupted	- Wire break, triac in controller defective - Primary winding of impulse transformer interrupted
	Secondary circuit interrupted before U_R pickoff point	- Wire break - Secondary winding of impulse transformer interrupted
③	U_R signal missing	- Measuring wire interrupted
④	Partial short-circuit (ΔR)	- Heatsealing band partially bypassed by conducting part (clamp, opposite heatsealing bar etc.)
⑤	Parallel circuit interrupted	- Wire break, heatsealing band break - Contacting to heatsealing band defective
⑥	Total short-circuit	- Heatsealing band installed incorrectly, insulation at heatsealing bar ends missing or incorrectly installed - Conducting part bypasses heatsealing band completely
⑦	U_R signal incorrect	- U_2 outside permissible range from 0.4...120VAC
⑧	I_R signal incorrect	- I_2 outside permissible range from 30...500A
	Turns through PEX-W2/W3 current transformer incorrect	- Check number of turns (two or more turns required for currents < 30A)
⑨	Internal controller fault	- Hardware fault (replace controller)

10 Factory settings

The CIRUS temperature controller UPT-640 (as of SW 100) is configured in the factory as follows:

<u>Values in the Settings and Configuration menus</u>	Settings menu	
	No. 101	Heatsealing temperature: 0°C
	No. 102	Preheating temperature: 0°C
	No. 103	Starting delay: 0s
	No. 104	Heatsealing time: 0.10s
	No. 105	Cooling value: Cooling time: 1.00 s Absolute cooling temperature: 50°C Relative cooling temperature: 40 % of heatsealing temperature
	No. 106	Hold mode: OFF
	No. 107	AUTOCAL temperature: 20°C
	No. 110	Correction factor Co: 100%
	No. 115	Release temperature: 0°C
	No. 116	Release delay: 0s
	No. 117	Release duration: 0s
	Configuration menu	
	No. 201	Language German This selection is NOT changed if the factory settings are restored with step 202 in the Config. menu.
	No. 203	Alloy 1700ppm
	No. 204	Temperature range: max. 300°C
	No. 206	Maximum temperature: 300°C
	No. 207	Set point reached: -10K
	No. 208	Set point exceeded: +10K
	No. 209	Time control: OFF
	No. 210	Cooling mode: Absolute
	No. 212	Relay K1 function: Active when temperature reached
	No. 213	Lock of „HAND“ key OFF
	No. 214	Cycle counter: 0
	No. 215	Alarm relay: Normal (contact closed by a fault)
	No. 216	Analog output: Actual temperature
	No. 217	Temperature diagnosis: OFF
	No. 218	Temp.diagnosis delay time: 0s
	No. 219	Heatup timeout: OFF
	No. 220	Measuring impulse length: Standard (1.7 ms)
	No. 221	Autocomp: OFF
	No. 222	"Output 1": Active if Tact = Tset, with latch function
	No. 224	Starting temperature: 100°C
	No. 225	Temperature unit: Celsius

10.1 Customer settings

The controller factory settings can be specified or restored with step 202 in the Configuration menu. You can also store customer settings in addition to the Ropex settings:



The following settings are possible:

1. **„Restore Ropex settings“
(Factory setting)**

Selecting this option restores the menu values listed in section 10 "Factory settings" on page 51. These values correspond to the factory settings with which the controller was delivered.

2. **„Define customer settings“**

Selecting this option saves the values that are currently set in the controller Settings and Configuration menus as "customer settings". These "customer settings" are independent of the Ropex settings. Machine-specific settings can be stored in the controller in this way.

3. **„Restore customer settings**

Selecting this option restores the "customer settings" that were saved as described in 2.

When the controller is first delivered, the "customer settings" are identical to the Ropex settings.

After pressing the "ENTER" key in this menu step, you are asked to confirm the new settings (safety query).

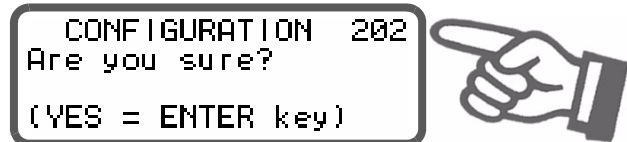

Another message appears if you now confirm these settings by pressing the "ENTER" key for approximately 2seconds.

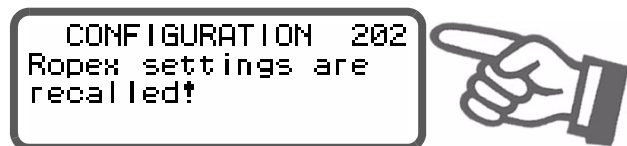

You can also cancel the new settings by pressing the "MENU", cursor "UP" or cursor "DOWN" keys. Step 203 then appears on the display.







The language which is selected with step 201 in the Configuration menu remains set even if the previous settings are restored.

11 Maintenance

The controller requires no special maintenance. Regular inspection and/or tightening of the terminals – including the terminals for the winding connections on

the impulse transformer – is recommended. Dust deposits on the controller can be removed with dry compressed air.

12 How to order

	<p>Contr. UPT - 640- . / . . . VAC</p> <ul style="list-style-type: none"> L / 230: LC display, line voltage 230VAC, Art. No. 664012 L / 400: LC display, line voltage 400VAC, Art. No. 664013 V / 230: VF display, line voltage 230VAC, Art. No. 664022 V / 400: VF display, line voltage 400VAC, Art. No. 664023 <p>Scope of supply: Controller includes connector plug-in parts (current transformer must be ordered separately)</p>
	<p>Current transformer PEX-W3 Art. No. 885105</p>
	<p>Line filter LF- . . 480</p> <ul style="list-style-type: none"> 06: Continuous current 6A, 480VAC, Art. No. 885500 35: Continuous current 35A, 480VAC, Art. No. 885506
	<p>Impulse transformer</p> <p>See ROPEX Application Report for design and ordering information</p>
	<p>Communication interface CI-USB-1 Art. No. 885650</p>
	<p>Temp. meter ATR- .</p> <ul style="list-style-type: none"> 3: 300°C range, Art. No. 882130 5: 500°C range, Art. No. 882150
	<p>Booster B- . . . 400</p> <ul style="list-style-type: none"> 075: Max. pulse load 75A, 400VAC, Art. No. 885301 100: Max. pulse load 100A, 400VAC, Art. No. 885304

For more accessories: ↪ "Accessories" leaflet

13 Index

A

Accessories 7
 Actual value output 31
 Adapter for top hat rail mounting 8
 Additional relay K1 9
 Alarm output 46
 Alarm relay 9, 20
 Alloy 18
 Ambient temperature 9
 Analog temperature meter 7
 Application 4
 Application Report 12, 14
 AUTOCAL 21, 32
 Automatic zero calibration 21, 32

B

Booster 6, 7, 16, 53
 Booster connection 38

C

Celsius °C 36
 Circuit breaker 13
 CI-USB-1 7, 38, 53
 Communication interface 7, 38, 53
 Controller configuration 18
 Controls 23
 Correction factor 34
 Current transformer 3, 6, 8, 14, 53
 Customer settings 52
 Cycle counter 35

D

Degree of protection 10
 Diagnostic interface 38
 Digital temperature meter 7
 Dimensions 11
 Disabling Configuration menu 37
 Display 23
 Display brightness 37

E

Error messages 46
 External switching amplifier 7, 16

F

Factory settings 18, 51
 Fahrenheit °F 36
 Fault areas 50
 Front cover 8

H

HEAT 22, 33
 Heating element 3, 4, 21

Heatsealing band type 9
 Heatup timeout 20
 Hold mode 35

I

Impulse transformer 3, 7, 13, 53
 Installation 10, 12

L

Line filter 3, 7, 13, 14, 53
 Line frequency 9
 Line voltage 9
 Locking the "HAND" key 36

M

Maintenance 52
 Manual mode 30
 Measurement cable 8
 Measuring impulse duration 36
 Modifications 8
 MODs 8
 Monitoring current transformer 8

O

Output 1 9, 19, 43

P

PEX-W2/-W3 3, 6
 PEX-W3 14, 53
 Power dissipation 9
 Power supply 13

R

Relay K1 19, 41
 Release Impulse 44
 Replacing the heating element 21
 "RESET" signal 34

S

Set point selection 9, 30
 Standby mode 37
 "START" signal 22, 33
 Starting temperature 35
 System diagnostics 38
 System monitoring 46

T

TCR 21
 Temperature coefficient 18, 21
 Temperature diagnosis 20
 Temperature indication 31
 Temperature meter 7, 31, 53

Temperature OK 9
Temperature OK signal 9
Temperature range 9, 18
Temperature setting 30
Temperature unit 36
Time control 18
Timer function 18, 33
Transformer 3, 7, 13, 53
Type of construction 9

U

Undervoltage detection 37

V

View of controller 17

Visualization software 38

W

Wiring 12, 13

Wiring diagram 15, 16